











WAGO Isolation Amplifiers and Signal Conditioners

WAGO Isolation Amplifiers and Signal Conditioners

		Page
	Isolation Amplifiers	
	2857 Series	250
	857 Series	252
	Current and Voltage Signal Conditioners	
	2857 Series	274
	857 Series	276
	Power Signal Conditioners	
	2857 Series	286
	857 Series	288
	Threshold Value Switches	
	2857 Series	296
	857 Series	302
	Temperature Signal Conditioners	
	857 Series	304
	2857 Series	318
	Potentiometer Signal Conditioner	
	857 Series	326
	Frequency Signal Conditioner	
	857 Series	328
	Configuration Software	
	Interface Configuration Software and Configuration App	332
	Accessories	
	Configuration Display, 2857 Series	334
	Bluetooth® Adapter	335
	WAGO USB Communication Cable, 750 Series	336
	Interface Adapter, 857 Series	337
	WAGO Interface Cable, 706 Series	340
	Switched-Mode Power Supply, 787 Series	342
	Supply and Through Module, 857 Series	338
Accessories, 857 Series	344	

WAGO Isolation Amplifiers Selection Guide

3

	Image	Description	Circuit Diagram	Input Signal			Power Supply U_s
				Current	Voltage	Bipolar Signals (I/U)	
Isolation Amplifiers							
Isolation Amplifiers		Isolation Amplifier; Configurable; with Digital Output		0 ... 1 mA 0 ... 10 mA 2 ... 10 mA 0 ... 20 mA 4 ... 20 mA 0 ... 100 mA	0 ... 5 V 1 ... 5 V 0 ... 10 V 2 ... 10 V 0 ... 220 V	± 1 mA; ± 10 mA; ± 20 mA; ± 100 mA ± 1 V; ± 10 V; ± 30 V; ± 100 V; ± 200 V	24 VDC
		Isolation Amplifier; Configurable; with Zero/Span Adjustment		0 ... 10 mA 2 ... 10 mA 0 ... 20 mA 4 ... 20 mA	0 ... 5 V 1 ... 5 V 0 ... 10 V 2 ... 10 V		24 VDC
		Isolation Amplifier; Configurable; with Digital Output		0 ... 10 mA 2 ... 10 mA 0 ... 20 mA 4 ... 20 mA	0 ... 5 V 1 ... 5 V 0 ... 10 V 2 ... 10 V	± 20 mA ± 10 V	24 VDC
		Isolation Amplifier; Configurable		$\pm 0,3 ... \pm 100$ mA	± 60 mV ... ± 200 V	$\pm 0,3 ... \pm 100$ mA ± 60 mV ... ± 200 V	24 VDC
		Bipolar Isolation Amplifier		0 ... 10 mA 2 ... 10 mA 0 ... 20 mA 4 ... 20 mA	0 ... 5 V 1 ... 5 V 0 ... 10 V 2 ... 10 V	± 10 mA ± 20 mA ± 5 V ± 10 V	24 VDC
		Isolation Amplifier; Pre-Configured		0 (4) ... 20 mA 0 ... 20 mA 4 ... 20 mA	0 (2) ... 10 V 0 ... 10 V 0 ... 10 V		24 VDC
Repeater Power Supply		Repeater Power Supply		0 ... 20 mA 4 ... 20 mA			24 VDC
Signal Splitters		Signal Splitter; with Current Output		0 ... 20 mA 4 ... 20 mA	0 ... 5 V 1 ... 5 V 0 ... 10 V 2 ... 10 V		24 VDC
		Signal Splitter; with Voltage/Current Output		0 ... 10 mA 2 ... 10 mA 0 ... 20 mA 4 ... 20 mA	0 ... 5 V 1 ... 5 V 0 ... 10 V 2 ... 10 V		24 VDC
Passive Isolators		Loop-Powered Isolation Amplifier		0 ... 5 mA 0 ... 10 mA 2 ... 10 mA 0 ... 20 mA 4 ... 20 mA	0 ... 1 V 0 ... 5 V 1 ... 5 V 0 ... 10 V 2 ... 10 V	± 5 mA ± 10 mA ± 20 mA ± 1 V; ± 5 V ± 10 V ± 20 V	via output circuit
		Passive Isolator; 1-Channel		0 (4) ... 20 mA			via input circuit
		Passive Isolator; 2-Channel		2 x 0 (4) ... 20 mA			via input circuit

Output Signal			Configuration	Specialty Functions	Item No.	Page
Current	Voltage	Bipolar Signals (I/U)				
0 ... 10 mA 2 ... 10 mA 0 ... 20 mA 4 ... 20 mA	0 ... 5 V 1 ... 5 V 0 ... 10 V 2 ... 10 V	±10 mA ±20 mA ±5 V ±10 V	DIP switch; Interface configuration software/app/display	Digital output (DO); Clipping; Simulation	2857-401	250
0 ... 20 mA 4 ... 20 mA	0 ... 5 V 1 ... 5 V 0 ... 10 V 2 ... 10 V		DIP switch	Zero/span adjustment	857-400	252
0 ... 10 mA 2 ... 10 mA 0 ... 20 mA 4 ... 20 mA	0 ... 5 V 1 ... 5 V 0 ... 10 V 2 ... 10 V		DIP switch; Interface configuration software/app	Digital output (DO); Clipping	857-401	254
0 ... 10 mA 2 ... 10 mA 0 ... 20 mA 4 ... 20 mA	0 ... 5 V 1 ... 5 V 0 ... 10 V 2 ... 10 V	±10 mA ±20 mA ±5 V ±10 V	DIP switch	Clipping	857-403	256
0 ... 10 mA 2 ... 10 mA 0 ... 20 mA 4 ... 20 mA	0 ... 5 V 1 ... 5 V 0 ... 10 V 2 ... 10 V	±10 mA ±20 mA ±5 V ±10 V	DIP switch	Zero/span adjustment	857-409	258
0 (4) ... 20 mA	0 (2) ... 10 V				857-411	260
0 ... 20 mA		857-412	261			
4 ... 20 mA		857-413	262			
		857-414	262			
		857-415	263			
		857-416	263			
0 ... 20 mA 4 ... 20 mA	0 ... 5 V 1 ... 5 V 0 ... 10 V 2 ... 10 V		DIP switch		857-420	264
2 x 0 (4) ... 20 mA			DIP switch		857-423	266
2 x 0 ... 20 mA 4 ... 20 mA	2 x 0 ... 10 V 2 ... 10 V		DIP switch		857-424	268
4 ... 20 mA			DIP switch	Zero/span adjustment	857-450	270
0 (4) ... 20 mA					857-451	272
2 x 0 (4) ... 20 mA					857-452	273

3

WAGO Current and Voltage Signal Conditioners Selection Guide

3

Image	Description	Circuit Diagram	Input Signal			Power Supply U _s
			Current	Voltage	Bipolar Signals (I/U)	
Current and Voltage Signal Conditioners						
	Through-Hole Current Signal Conditioner		100 A AC/DC			24 VDC
	Current Signal Conditioner		1 A AC/DC 5 A AC/DC			24 VDC
	Current Signal Conditioner; for Rogowski Coils		Rogowski coils 500 AAC 2000 AAC			24 VDC
	Voltage Signal Conditioner		300 V AC/DC			24 VDC
	1-Phasen- Leistungsmessumformer		1 A AC/DC (IN 3.1); 5 A AC/DC (IN 3.2); 8 A AC/DC (IN 3.3)	500 VAC/VDC (IN 2.1); 300 VAC/VDC (IN 2.1); 250 VAC/VDC (IN 2.2); 50 VAC/VDC (IN 2.3)		24 VDC
	Power Signal Conditioner		300 V AC/DC (5 A)			24 VDC
	Milivolt Signal Conditioner			0 ... 200 mV 0 ... 1000 mV	±100 mV	24 VDC
	Current Signal Conditioner		0 ... 5 A AC/DC (IN 1; block arrangement); 0 ... 6 A AC/DC (IN 1; individual arrangement); 0 ... 1 A AC/DC (IN 2)			24 VDC
	3-Phase Power Measurement Module		4 x 1 AAC	3 x 300 VAC		24 VDC
	3-Phase Power Measurement Module		4 x 5 AAC	3 x 300 VAC		24 VDC
	3-Phase Power Measurement Module		Rogowski coils 4x 4000 AAC	3 x 300 VAC		24 VDC

Output Signal			Configuration	Specialty Functions	Item No.	Page
Current	Voltage	Bipolar Signals (I/U)				
0 ... 10 mA 2 ... 10 mA 0 ... 20 mA 4 ... 20 mA	0 ... 5 V 1 ... 5 V 0 ... 10 V 2 ... 10 V	±10 mA ±20 mA ±5 V ±10 V	DIP switch; Interface configuration software/app/display	Digital output (DO); Clipping; Zero/span adjustment; Simulation	2857-550	274
0 ... 10 mA 2 ... 10 mA 0 ... 20 mA 4 ... 20 mA	0 ... 5 V 1 ... 5 V 0 ... 10 V 2 ... 10 V		DIP switch; Interface configuration software/app	Digital output (DO); Clipping	857-550	276
0 ... 10 mA 2 ... 10 mA 0 ... 20 mA 4 ... 20 mA	0 ... 5 V 1 ... 5 V 0 ... 10 V 2 ... 10 V		DIP switch; Interface configuration software/app	Digital output (DO); Clipping	857-552	280
0 ... 10 mA 2 ... 10 mA 0 ... 20 mA 4 ... 20 mA	0 ... 5 V 1 ... 5 V 0 ... 10 V 2 ... 10 V		DIP switch; Interface configuration software/app	Digital output (DO); Clipping	857-560	282
		±24 mA ±12 V	Interface configuration software/display	Digital output (DO)	2857-569	286
0 ... 10 mA 2 ... 10 mA 0 ... 20 mA 4 ... 20 mA	0 ... 5 V 1 ... 5 V 0 ... 10 V 2 ... 10 V		DIP switch; Interface configuration software/app	Digital output (DO); Clipping	857-569	288
0 ... 10 mA 2 ... 10 mA 0 ... 20 mA 4 ... 20 mA	0 ... 5 V 1 ... 5 V 0 ... 10 V 2 ... 10 V		DIP switch; Interface configuration software/app	Clipping	857-819	284
0 ... 10 mA; 2 ... 10 mA; 0 ... 20 mA; 4 ... 20 mA (can be inverted, also bipolar)	0 ... 5 V; 1 ... 5 V; 0 ... 10 V; 2 ... 10 V (can be inverted, also bipolar)		DIP switch; Interface configuration software		857-551	278
			Interface configuration software		2857-570/024-001	290
			Interface configuration software		2857-570/024-005	292
			Interface configuration software		2857-570/024-000	294

WAGO Temperature Signal Conditioners

Selection Guide

3

Image	Description	Circuit Diagram	Input Signal	Sensor Connection	Power Supply U_s
Temperature Signal Conditioners					
	Temperature Signal Conditioner; for Pt and Resistance Sensors		Pt sensors: Pt100, Pt200, Pt500, Pt1000; Resistance sensors: 0 ... 1 kΩ; 0 ... 4.5 kΩ	2-, 3-, 4-wire connection	24 VDC
	Temperature Signal Conditioner; for Pt and Resistance Sensors		Pt sensors: Pt100, Pt200, Pt500, Pt1000; Resistance sensors: 0 ... 1 kΩ; 0 ... 4.5 kΩ	2-, 3-, 4-wire connection	24 VDC
	Temperature Signal Conditioner; for Pt46 and Cu53 Sensors		Pt46; Cu53	2-, 3-, 4-wire connection	24 VDC
	Temperature Signal Conditioner; for Thermocouples		Thermocouples: Type J, K		24 VDC
	Temperature Signal Conditioner; for Thermocouples		Thermocouples: Type J, K, E, R, N, S, T, B, S		24 VDC
	Temperature Signal Conditioner; for Thermocouples		Thermocouples: Type K, S, B, R		24 VDC
	Loop-Powered RTD Temperature Signal Conditioner		Pt sensors: Pt100, Pt200, Pt500, Pt1000; Resistance sensors: 0 ... 1 kΩ; 0 ... 4.5 kΩ	2-, 3-, 4-wire connection	via output circuit
	Temperature Signal Conditioner; for Ni Sensors		Ni sensors: Ni100, Ni120, Ni200, Ni500, Ni1000	2-, 3-, 4-wire connection	24 VDC
	Temperature Signal Conditioner; for KTY Sensors		KTY sensors	2-wire connection	24 VDC
	RTD/TC Temperature Signal Conditioner; Analog		RTD sensors; Potentiometers; Resistors; Thermocouples	2-, 3-, 4-wire connection; Differential measurement; Potentiometer	9.6 ... 31.2 VDC
	RTD/TC Temperature Signal Conditioner; Serial		RTD sensors; Potentiometers; Resistors; Thermocouples	2-, 3-, 4-wire connection; Differential measurement; Potentiometer	9.6 ... 31.2 VDC









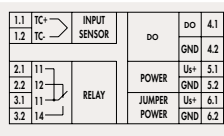

Sensor Temperature Range	Output Signal			Configuration	Specialty Functions	Item No.	Page
	Current	Voltage	RS-485				
-200 ... +850 °C	0 ... 10 mA 2 ... 10 mA 0 ... 20 mA 4 ... 20 mA	0 ... 5 V 1 ... 5 V 0 ... 10 V 2 ... 10 V		DIP switch	Clipping	857-800	304
-200 ... +850 °C	0 ... 10 mA 2 ... 10 mA 0 ... 20 mA 4 ... 20 mA	0 ... 5 V 1 ... 5 V 0 ... 10 V 2 ... 10 V		DIP switch; Configuration software/app	Clipping	857-801	306
-200 ... +300 °C (Pt46) 0 ... +180 °C (Cu53)	0 ... 10 mA 2 ... 10 mA 0 ... 20 mA 4 ... 20 mA	0 ... 5 V 1 ... 5 V 0 ... 10 V 2 ... 10 V		DIP switch		857-808	308
Type J: -150 ... +1200 °C; Type K: -150 ... +1350 °C	0 ... 10 mA 2 ... 10 mA 0 ... 20 mA 4 ... 20 mA	0 ... 5 V 1 ... 5 V 0 ... 10 V 2 ... 10 V		DIP switch	Clipping	857-810	310
Type J: -150 ... +1200 °C; Type K: -150 ... +1350 °C	0 ... 10 mA 2 ... 10 mA 0 ... 20 mA 4 ... 20 mA	0 ... 5 V 1 ... 5 V 0 ... 10 V 2 ... 10 V		DIP switch; Configuration software/app	Clipping	857-811	312
Type K: -150 ... +1200 °C; Type S: 0 ... +1600 °C; Type B: 600 ... +1800 °C; Type R: 0 ... +1600 °C	0 ... 10 mA 2 ... 10 mA 0 ... 20 mA 4 ... 20 mA	0 ... 5 V 1 ... 5 V 0 ... 10 V 2 ... 10 V		DIP switch		857-812	314
-200 ... +850 °C	4 ... 20 mA 20 ... 4 mA			DIP switch		857-815	416
	0 ... 10 mA 2 ... 10 mA 0 ... 20 mA 4 ... 20 mA	0 ... 5 V 1 ... 5 V 0 ... 10 V 2 ... 10 V		DIP switch	Clipping	857-818	322
	0 ... 10 mA 2 ... 10 mA 0 ... 20 mA 4 ... 20 mA	0 ... 5 V 1 ... 5 V 0 ... 10 V 2 ... 10 V		DIP switch	Digital output (DO); Clipping	857-820	324
-200 ... +850 °C; 0 ... 10 kΩ; Type J: -210 ... +1200 °C; Type K: -200 ... +1372 °C	-24 ... +24 mA (load impedance ≤ 600 Ω)	-12 ... +12 V (load impedance ≥ 2 kΩ)		Configuration software/ display	Digital output DO; Relay with 1 changeover contact (250 VAC / 6 A); Simulation	2857-535	318
-200 ... +850 °C; 0 ... 10 kΩ; Type J: -210 ... +1200 °C; Type K: -200 ... +1372 °C			Modbus RTU	Configuration software/ display; Rotary encoder switch	Relay with 1 changeover con- tact (250 VAC / 6 A); Simulation	2857-535/000-001	320

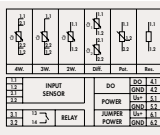
WAGO Signal Conditioners with Specialty Functions

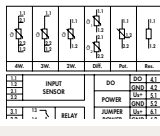
WAGO Threshold Value Switches

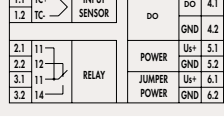
Selection Guide

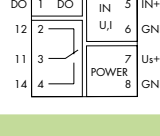
3

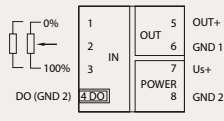
Image	Description	Circuit Diagrams	Input Signal			
			Frequencies			
Frequency Signal Conditioner						
	Frequency Signal Conditioner		Frequency signals; NAMUR/NPN or PNP sensors 0.1 ... 120 kHz			
Image	Description	Circuit Diagrams	Input Signal			
			Current	Voltage	Bipolar Signals (I/U)	Sensors
Threshold Value Switches						
	RTD Threshold Value Switch					0 ... 100 kΩ; Pt100; Pt200; Pt500; Pt1000; Pt5000; Pt10,000; Pt10 ... 20,000
	RTD Threshold Value Switch					0 ... 100 kΩ; Pt100; Pt200; Pt500; Pt1000; Pt5000; Pt10,000; Pt10 ... 20,000
	Thermocouple Threshold Value Switch					Type J, K, E, N, R, S, T, B, C
	Analog Threshold Value Switch		0 ... 10 mA 2 ... 10 mA 0 ... 20 mA 4 ... 20 mA	0 ... 5 V; 1 ... 5 V; 0 ... 10 V; 2 ... 10 V; 0 ... 15 V; 0 ... 30 V	±10 mA ±20 mA ±5 V ±10 V	
Image	Description	Circuit Diagrams	Input Signal			
			Potentiometers		Resistors	
Signal Conditioners with Specialty Functions						
	Potentiometer Signal Conditioner		0 ... 100 kΩ		10 ... 100 kΩ	

Power Supply U_s	Output Signal		Configuration	Specialty Functions	Item No.	Page
	Current	Voltage				
24 VDC	0 ... 10 mA 2 ... 10 mA 0 ... 20 mA 4 ... 20 mA	0 ... 5 V 1 ... 5 V 0 ... 10 V 2 ... 10 V	DIP switch; Interface configuration software/app	Clipping	857-500	328
Power Supply U_s	Output Signal		Configuration	Specialty Functions	Item No.	Page
	Relay (1 changeover contact)	Relay (1 make contact)				
24 VDC		250 VAC 6 A	DIP switch; Interface configuration software/app/display	Digital output DO; Relay with 1 make contact (250 VAC / 6 A); Simulation	2857-533	296
24 VDC		250 VAC 6 A	Interface configuration software/display	Digital output DO; Relay with 1 make contact (250 VAC / 6 A); Simulation	2857-533/000-001	298
24 VDC	250 VAC 6 A		DIP switch; Interface configuration software/app/display	Digital output DO; Relay with 1 changeover contact (250 VAC / 6 A); Simulation	2857-534	300
24 VDC	250 VAC 6 A		DIP switch; Push/slide switch; Interface configuration software/app	Digital output DO; Relay with 1 changeover contact (250 VAC/6 A)	857-531	302
Power Supply U_s	Output Signal		Configuration	Specialty Functions	Item No.	Page
	Current	Voltage				
24 VDC	0 ... 10 mA 2 ... 10 mA 0 ... 20 mA 4 ... 20 mA	0 ... 5 V 1 ... 5 V 0 ... 10 V 2 ... 10 V	DIP switch; Push/slide switch; Interface configuration software/app	Clipping	857-809	326

Approvals Overview

3

Approvals										Item Description	Item Number	Page
IECEX	ATEX	Marine Approvals					ANSI/ISA 12.12.01	UL 508	UL 61010-2-201			
		PRS (Polski Rejestr Statkow)	NKK (Nippon Kaiji Kyokai)	GL (Germ Lloyd)	DNV (Det Norske Veritas)	BV (Bureau Veritas)						
Isolation Amplifiers										Isolation Amplifier; Configurable; with Digital Output	2857-401	250
										Isolation Amplifier; Configurable; with Zero/Span Adjustment	857-400	252
										Isolation Amplifier; Configurable; with Digital Output	857-401	254
										Isolation Amplifier; Configurable	857-403	256
										Bipolar Isolation Amplifier	857-409	258
										Isolation Amplifier; Pre-Configured	857-411	260
										Isolation Amplifier; Pre-Configured	857-412	261
										Isolation Amplifier; Pre-Configured	857-413	262
										Isolation Amplifier; Pre-Configured	857-414	262
										Isolation Amplifier; Pre-Configured	857-415	263
										Isolation Amplifier; Pre-Configured	857-416	263
										Repeater Power Supply	857-420	264
										Signal Splitter	857-423	266
										Signal Splitter (I/U)	857-424	268
										Loop-Powered Isolation Amplifier	857-450	270
										Passive Isolator; 1-Channel	857-451	272
										Passive Isolator; 2-Channel	857-452	273
Current and Voltage Signal Conditioners										Through-Hole Current Signal Conditioner	2857-550	274
										Current Signal Conditioner	857-550	276
										Current Signal Conditioner; for Rogowski Coils	857-552	280
										Voltage Signal Conditioner	857-560	282
											2857-569	286
										Power Signal Conditioner	857-569	288
										Milivolt Signal Conditioner	857-819	284
										Current Signal Conditioner	857-551	278
										3-Phase Power Signal Conditioner; 1 A	2857-570/024-001	290
										3-Phase Power Signal Conditioner; 5 A	2857-570/024-005	292
										3-Phase Power Signal Conditioner; RC	2857-570/024-000	294
Temperature Signal Conditioners										Temperature Signal Conditioner; for Pt and Resistance Sensors	857-800	304
										Temperature Signal Conditioner; for Pt and Resistance Sensors	857-801	306
										Temperature Signal Conditioner; for Thermocouples	857-810	310
										Temperature Signal Conditioner; for Thermocouples	857-811	312
										Temperature Signal Conditioner; for Thermocouples	857-812	314
										Temperature Signal Conditioner; for Pt46 and Cu53 Sensors	857-808	308
										Loop-Powered RTD Temperature Signal Conditioner	857-815	316
										Temperature Signal Conditioner; for Ni Sensors	857-818	322
										Temperature Signal Conditioner; for KTY Sensors	857-820	324
										RTD/TC Temperature Signal Conditioner; Analog	2857-535	318
										RTD/TC Temperature Signal Conditioner; Serial	2857-535/000-001	320
Threshold Value Switches										RTD Threshold Value Switch	2857-533	296
											2857-533/000-001	298
										Thermocouple Threshold Value Switch	2857-534	300
										Analog Threshold Value Switch	857-531	302
Specialty Functions										Frequency Signal Conditioner	857-500	328
										Potentiometer Signal Conditioner	857-809	326
Accessories										Supply and Through Module	857-979	338
										Interface Adapter for System Wiring	857-980	337

Signs and Symbols

Specialty Functions:



Zero/span adjustment



Clipping capability



Digital output (DO)



Relay, 1 changeover contact



Relay, 1 make contact



Simulation

Configuration:



DIP switch



Rotary coding switch



Interface configuration software



Interface configuration app



Interface configuration display



Push/slide switch

Isolation Amplifier; Configurable; with Digital Output

2857 Series



3

1.1	U+	INPUT VOLTAGE	OUTPUT	OUT+	4.1
1.2	U-			OUT-	4.2
2.1	I+	INPUT CURRENT	POWER	Us+	5.1
2.2	I-			GND	5.2
3.1	DO (GND)	DO	JUMPER POWER	Us+	6.1
3.2	DI (GND)	DI (HOLD)		GND	6.2

Isolation Amplifier; Bipolar current and voltage input signal; Bipolar current and voltage output signal; Digital output; Supply voltage: 24 VDC; Module width: 12.5 mm

Item No.	Pack. Unit
2857-401	1

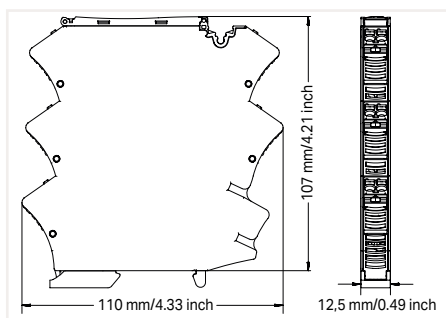

Short description:

WAGO's isolation amplifier converts, amplifies, filters, and electrically isolates analog signals.

Features:

- Analog unipolar/bipolar signals at both input and output
- Digital signal output reacts to configured measurement range limits (configurable on/off switching delay and threshold value switch function with up to two threshold values)
- Digital HOLD input freezes the output signal
- Clipping capability provides analog signal limitation to output end values
- Adjustable software/hardware filter
- Input/output response simulation via configuration display
- Safe 3-way isolation with 4 kV test voltage per EN 61140

Note:

Additional setting options via interface configuration software/app

» Configuration software	Page 332
» Configuration app	Page 333
» Configuration display	Page 334
» Accessories	Page 344

Configuration	
Configuration options	DIP switch; Interface configuration software; Interface configuration app; Configuration display
Input	
Input signal type	Voltage; Current
Input signal (voltage)	±1 V; 0 ... 1 V; ±5 V; 0 ... 5 V; 1 ... 5 V; ±10 V; 0 ... 10 V; 2 ... 10 V; ±30 V; 0 ... 30 V; ±100 V; 0 ... 100 V; ±200 V; 0 ... 220 V
Input signal (current)	±1 mA; 0 ... 1 mA; ±10 mA; 0 ... 10 mA; 2 ... 10 mA; ±20 mA; 0 ... 20 mA; 4 ... 20 mA; ±100 mA; 0 ... 100 mA
Input resistance (current input)	≤ 50 Ω
Input resistance (voltage input)	≥ 1 MΩ
Input current (max.)	± 120 mA
Input voltage (max.)	±250 V
Input – Digital	
Hold signal	11.8 V ... U _S
Output	
Output signal type	Current; Voltage
Output signal (voltage)	±5 V; 0 ... 5 V; 1 ... 5 V; ±10 V; 0 ... 10 V; 2 ... 10 V
Output signal (current)	±10 mA; 0 ... 10 mA; 2 ... 10 mA; ±20 mA; 0 ... 20 mA; 4 ... 20 mA
Load impedance (voltage output)	≥ 1 kΩ
Load impedance (current output)	≤ 600 Ω
Output – Digital	
Max. switching voltage (DO)	Supply voltage applied: -0.3 V
Max. continuous current (DO)	100 mA (no internal restriction)
Number of switching thresholds (DO)	1 or 2 (adjustable)
Configurable rise/fall delay time (DO)	0 ... 60 s (via software)
Signal Processing	
Limit frequency	10 kHz / 5 kHz / 100 Hz / 30 Hz (configurable via DIP switch or software)
Software filter; adjustable	Moving average value (filter level: 30)
Step response (typ.)	1 ms
Measurement Error	
Transmission error (typ.)	≤ 0.1 % of upper-range value
Temperature coefficient	≤ 0.01%/K
Power Supply	
Power supply type	24 VDC
Nominal supply voltage U _S	24 VDC
Supply voltage range	±30 %
Power consumption at nominal supply voltage	≤ 70 mA (+ IDO)
Safety and Protection	
Test voltage (input/output/supply)	4 kV AC; 50 Hz; 1 min
Protection type	IP20
Connection Data	
Connection technology	Push-in CAGE CLAMP®
WAGO Connector	picoMAX® 5.0
Solid conductor	0.2 ... 2.5 mm ² / 24 ... 12 AWG
Fine-stranded conductor	0.2 ... 2.5 mm ² / 24 ... 12 AWG
Strip length	9 ... 10 mm / 0.35 ... 0.39 inch
Geometric Data	
Width	12.5 mm / 0.492 inch
Height from upper-edge of DIN-rail	107 mm / 4.213 inch
Depth	110 mm / 4.331 inch
Mechanical Data	
Mounting type	DIN-35 rail
Material Data	
Weight	85.9 g

Specialty Functions:



Configuration via:



Environmental Requirements

Surrounding air temperature (operation)	-40 ... +70 °C
Surrounding air temperature (storage)	-40 ... +85 °C

Standards and Specifications

Conformity marking	CE
EMC immunity to interference	EN 61000-6-2; EN 61326-2-3; EN 50121-3-2
EMC emission of interference	EN 61000-6-4; EN 61326-2-3; EN 50121-3-2
Standards/specifications	EN 60664-1; EN 61373

2857-401

DIP Switch Adjustability

● = ON **Default**

DIP Switch S1

Input													
1	Signal	2	Polarity	3	4	5	Range / mA	Range / V	6	Inverted Characteristic	7	8	Limit Frequency
	Current		Unipolar				0 ... 20	0 ... 10		Not inverted			10 kHz
●	Voltage	●	Bipolar *	●			0 ... 1	0 ... 1	●	Inverted	●		5 kHz
					●		0 ... 5	0 ... 5				●	100 Hz
				●	●		0 ... 10	1 ... 5				●	30 Hz
						●	2 ... 10	2 ... 10					
				●		●	4 ... 20	0 ... 30					
					●	●	0 ... 50	0 ... 100					
				●	●	●	0 ... 100	0 ... 220					

DIP Switch S1

Output				DIP Switch S2			
9	Signal	10	Polarity	1	2	Range / mA	Range / V
	Current		Unipolar			0 ... 20	0 ... 10
●	Voltage	●	Bipolar *	●		4 ... 20	2 ... 10
					●	0 ... 10	0 ... 5
				●	●	2 ... 10	1 ... 5

DIP Switch S2

Output						Digital Output (DO)	
3	4	Measuring Range Underflow		Measuring Range Overflow		5	6
		Lower limit of output range -5% **		Upper limit of output range +2.5% **			
●		Lower limit of output range		Upper limit of output range +2.5%		●	
	●	Lower limit of output range		Upper limit of output range			●
	●	Lower limit of output range -5%		Upper limit of output range +5%		●	●

* Bipolar only applies to ranges starting with 0.

** acc. to NAMUR NE 43

Isolation Amplifier; Configurable; with Zero/Span Adjustment

857 Series

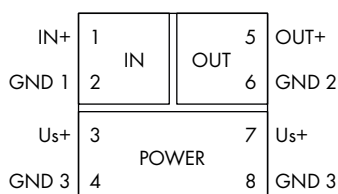

Isolation Amplifier; Current and voltage input signal; Current and voltage output signal; Zero/span adjustment; Supply voltage: 24 VDC; Module width: 6 mm

Item No.	Pack. Unit
857-400	1

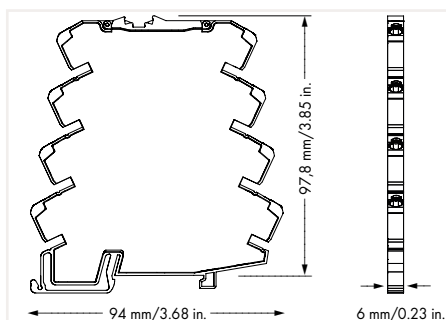

Short description:

WAGO's configurable isolation amplifier converts, amplifies, filters, and electrically isolates standard analog signals.

Features:

- Zero/span adjustment across the entire measurement range
- Calibrated measurement range switching
- Switchable limit frequency
- Safe 3-way isolation with 2.5 kV test voltage per EN 61140

Specialty Functions:



Configuration via:



Configuration

Configuration options	DIP switch
-----------------------	------------

Input

Input signal type	Voltage; Current
Input signal (voltage)	0 ... 5 V; 1 ... 5 V; 0 ... 10 V; 2 ... 10 V (calibrated switching)
Input signal (current)	0 ... 20 mA; 4 ... 20 mA (calibrated switching)
Input resistance (current input)	≤ 50 Ω
Input resistance (voltage input)	≥ 1MΩ
Input current (max.)	50 mA
Input voltage (max.)	30 V
Zero/span adjustment	±3 % of upper range value

Output

Output signal type	Current; Voltage
Output signal (voltage)	0 ... 5 V; 1 ... 5 V; 0 ... 10 V; 2 ... 10 V (calibrated switching)
Output signal (current)	0 ... 20 mA; 4 ... 20 mA; 0 ... 10 mA; 2 ... 10 mA (calibrated switching)
Load impedance (voltage output)	≥ 2 kΩ
Load impedance (current output)	≤ 600 Ω

Signal Processing

Limit frequency	100 Hz / 5 kHz (configurable via DIP switch)
Step response (typ.)	3.5 ms (100 Hz); 100 μs (5 kHz)

Measurement Error

Transmission error (typ.)	≤ 0.1 % of upper-range value
Transmission error (max.)	≤ 0.2 % of upper-range value
Temperature coefficient	≤ 0.01%/K

Power Supply

Power supply type	24 VDC
Nominal supply voltage U_s	24 VDC
Supply voltage range	±30 %
Power consumption at nominal supply voltage	≤ 25 mA

Safety and Protection

Test voltage (input/output/supply)	2.5 kVAC; 50 Hz; 1 min
Protection type	IP20

Connection Data

Connection technology	Push-in CAGE CLAMP®
Solid conductor	0.08 ... 2.5 mm ² / 28 ... 14 AWG
Fine-stranded conductor	0.34 ... 2.5 mm ² / 22 ... 14 AWG
Strip length	9 ... 10 mm / 0.35 ... 0.39 inch

Geometric Data

Width	6 mm / 0.236 inch
Height from upper-edge of DIN-rail	97.8 mm / 3.85 inch
Depth	94 mm / 3.701 inch

Mechanical Data

Mounting type	DIN-35 rail
---------------	-------------

Material Data

Weight	36.8 g
--------	--------

Environmental Requirements

Surrounding air temperature (operation)	-25 ... +70 °C
Surrounding air temperature (storage)	-40 ... +85 °C
Relative humidity	5 ... 95 % (no condensation permissible)
Operating altitude (max.)	2000 m

Standards and Specifications

Conformity marking	CE
EMC immunity to interference	EN 61000-6-2
EMC emission of interference	EN 61000-6-4

Isolation Amplifier; Configurable; with Digital Output 857 Series

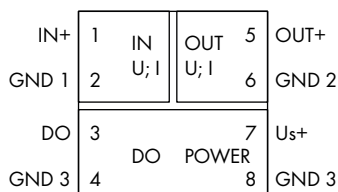
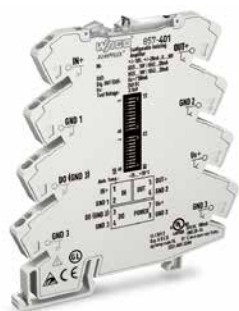

Isolation Amplifier; Current and voltage input signal; Current and voltage output signal; Digital output; Supply voltage: 24 VDC; Module width: 6 mm

Item No.	Pack. Unit
857-401	1

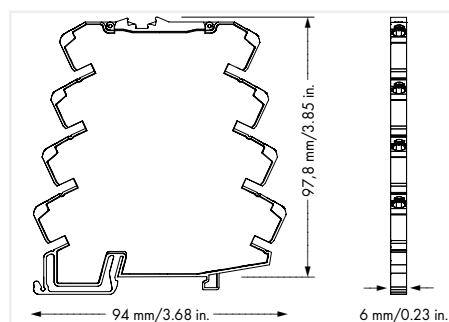

Short description:

WAGO's configurable isolation amplifier converts, amplifies, filters, and electrically isolates standard analog signals.

Features:

- PC configuration interface
- Digital switching output
- Calibrated measurement range switching
- Unipolar/bipolar standard analog signals at input
- Switchable clipping
- Limitation of standard analog signals to upper range values
- Safe 3-way isolation with 2.5 kV test voltage per EN 61140

Specialty Functions:



Configuration via:



» Configuration software	Page 332
» Configuration app	Page 333
» Accessories	Page 344

Configuration

Configuration options	DIP switch; Interface configuration software; Interface configuration app
-----------------------	---

Input

Input signal type	Voltage; Current
Input signal (voltage)	± 10 V; 0 ... 30 V
Input signal (current)	± 20 mA
Input resistance (current input)	≤ 200 Ω
Input resistance (voltage input)	≥ 100 k Ω
Input current (max.)	22 mA
Input voltage (max.)	31 V
Measurement span (voltage)	1 V
Measurement span (current)	2 mA

Output

Output signal type	Current; Voltage
Output signal (voltage)	0 ... 5 V; 1 ... 5 V; 0 ... 10 V; 2 ... 10 V
Output signal (current)	0 ... 10 mA; 2 ... 10 mA; 2 ... 20 mA; 4 ... 20 mA
Load impedance (voltage output)	≥ 2 k Ω
Load impedance (current output)	≤ 600 Ω

Output – Digital

Max. switching voltage (DO)	Supply voltage applied
Max. continuous current (DO)	100 mA (no internal restriction)
Number of switching thresholds (DO)	1 (adjustable)

Signal Processing

Step response (typ.)	8 ms
----------------------	------

Measurement Error

Transmission error (typ.)	≤ 0.1 % of upper-range value
Temperature coefficient	$\leq 0.01\%/K$

Power Supply

Power supply type	24 VDC
Nominal supply voltage U _S	24 VDC
Supply voltage range	± 30 %
Power consumption at nominal supply voltage	≤ 40 mA (+ IDO)

Safety and Protection

Test voltage (input/output/supply)	2.5 kVAC; 50 Hz; 1 min
Protection type	IP20

Connection Data

Connection technology	Push-in CAGE CLAMP®
Solid conductor	0.08 ... 2.5 mm ² / 28 ... 14 AWG
Fine-stranded conductor	0.34 ... 2.5 mm ² / 22 ... 14 AWG
Strip length	9 ... 10 mm / 0.35 ... 0.39 inch

Geometric Data

Width	6 mm / 0.236 inch
Height from upper-edge of DIN-rail	97.8 mm / 3.85 inch
Depth	94 mm / 3.701 inch

Mechanical Data

Mounting type	DIN-35 rail
---------------	-------------

Material Data

Weight	37 g
--------	------

Environmental Requirements

Surrounding air temperature (operation)	-25 ... +70 °C
Surrounding air temperature (storage)	-40 ... +85 °C
Relative humidity	5 ... 95 % (no condensation permissible)
Operating altitude (max.)	2000 m

Standards and Specifications

Conformity marking	CE
EMC immunity to interference	EN 61000-6-2; EN 61326-1; EN 50121-3-2
EMC emission of interference	EN 61000-6-3; EN 61326-1
Standards/specifications	EN 61373

857-401

DIP Switch Adjustability

● = ON Default

Input Signal Start Value													Input Signal End Value																					
DIP S1													DIP S1			DIP S2			DIP S1			DIP S2												
1	2	3	4	5	6	7	V	mA	2	3	4	5	6	7	V	mA	8	9	10	1	2	3	V	mA	8	9	10	1	2	3	V	mA		
							0	0							●	5.5	11							10	20							●	5.5	11
●							-10	-20	●						●	6	12	●						-10	-20	●						●	6	12
	●						-9.5	-19		●					●	6.5	13		●					-9.5	-19		●					●	6.5	13
	●	●					-9	-18	●	●					●	7	14		●	●				-9	-18		●	●				●	7	14
		●					-8.5	-17			●				●	7.5	15			●				-8.5	-17			●				●	7.5	15
	●	●					-8	-16	●	●					●	8	16		●	●				-8	-16		●	●				●	8	16
		●	●				-7.5	-15		●	●				●	8.5	17		●	●				-7.5	-15		●	●				●	8.5	17
	●	●	●				-7	-14	●	●	●				●	9	18		●	●	●			-7	-14		●	●	●			●	9	18
			●				-6.5	-13				●			●	9.5	19				●			-6.5	-13				●			●	9.5	19
	●		●				-6	-12	●			●			●	10	20		●		●			-6	-12		●		●			●	10	20
	●	●		●			-5.5	-11		●	●				●	10.5			●	●				-5.5	-11		●	●				●	10.5	
	●	●	●				-5	-10	●	●	●				●	11			●	●	●			-5	-10		●	●	●			●	11	
		●	●	●			-4.5	-9			●				●	11.5				●	●			-4.5	-9			●	●			●	11.5	
	●		●	●			-4	-8	●	●	●				●	12			●		●	●		-4	-8		●		●	●		●	12	
		●	●	●			-3.5	-7		●	●	●			●	13				●	●	●		-3.5	-7			●	●	●		●	13	
	●	●	●	●			-3	-6	●	●	●	●			●	14			●	●	●	●		-3	-6		●	●	●	●		●	14	
			●				-2.5	-5				●	●		●	15					●			-2.5	-5				●			●	15	
	●			●			-2	-4	●				●		●	16			●					-2	-4		●					●	16	
	●	●		●			-1.5	-3		●		●	●		●	17			●	●				-1.5	-3		●	●				●	17	
	●	●	●				-1	-2	●	●		●	●		●	18			●	●	●			-1	-2		●	●	●			●	18	
		●		●			-0.5	-1			●		●		●	19				●				-0.5	-1			●				●	19	
	●	●		●			0	0	●		●		●		●	20			●	●				0	0		●	●				●	20	
		●	●				0.5	1		●	●		●		●	21				●	●			0.5	1			●	●			●	21	
	●	●	●				1	2	●	●	●		●		●	22			●	●	●			1	2		●	●	●			●	22	
			●	●			1.5	3				●	●		●	23					●	●		1.5	3				●	●		●	23	
	●		●	●			2	4	●			●	●		●	24			●		●	●		2	4		●		●	●		●	24	
		●		●			2.5	5		●		●	●		●	25				●		●		2.5	5			●		●		●	25	
	●	●		●			3	6	●	●	●	●			●	26			●	●		●		3	6		●	●		●		●	26	
		●	●	●			3.5	7			●	●	●		●	27				●	●	●		3.5	7			●	●	●		●	27	
	●		●	●			4	8	●		●	●	●		●	28			●		●	●		4	8		●		●	●		●	28	
		●	●	●			4.5	9		●	●	●	●		●	29				●	●	●		4.5	9			●	●	●		●	29	
	●	●	●	●			5	10	●	●	●	●	●		●	30			●	●	●	●		5	10		●	●	●	●		●	30	

DIP Switch S2

Output Signal			Measuring Range Underflow		Measuring Range Overflow		Digital Output DO Signaling	
4	5	6	7	8	9	10	9	10
			0 ... 20 mA		Lower limit of output range	Upper limit of output range		
●			4 ... 20 mA		-5 % *	+2.5 % *		DO not active
	●		0 ... 10 mA	●	Lower limit of output range	Upper limit of output range	●	GND → U _N (switching)
	●	●	2 ... 10 mA		Lower limit of output range	Upper limit of output range	●	U _N → GND (switching)
			0 ... 10 V		Lower limit of output range	Upper limit of output range		
●	●		2 ... 10 V	●	Lower limit of output range	Upper limit of output range		
			0 ... 5 V		Lower limit of output range	Upper limit of output range		
●	●	●	1 ... 5 V	●	Lower limit of output range	Upper limit of output range		

*acc. to NAMUR NE 43

Digital Output DO/Signaling

The digital output (DO) signals error messages and can be configured as follows: 24 V → 0 V / 0 V → 24 V.

In order to increase the switching current of the DO, the latter may be expanded by a relay. Thanks to the common housing shape for the 857 Series, for example, a 857-304 Relay can be snapped in next to it. This output can be quickly and easily expanded to a switching current of 6A by simply using an adjacent jumper (859-402).

Isolation Amplifier; Configurable; with Zero/Span Adjustment

857 Series

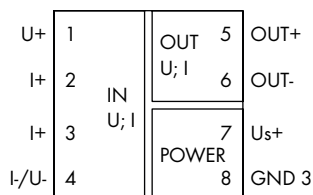

Isolation Amplifier; Current and voltage input signal; Bipolar current and voltage output signal; Zero/span adjustment; Supply voltage: 24 VDC; Module width: 6 mm

Item No.	Pack. Unit
857-403	1

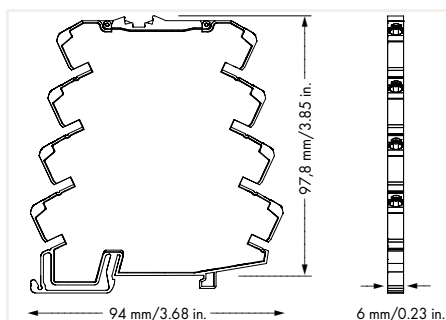

Short description:

This isolation amplifier converts standard unipolar/bipolar signals, as well as amplifies, filters and electrically isolates standard analog signals.

Features:

- Overload protection of current input via resettable fuse
- Calibrated measurement range switching for all 456 signals
- Unipolar/bipolar standard analog signals at both input/output
- Switchable limit frequency
- Clipping capability for analog signal limitation to output end values
- Safe 3-way isolation with 2.5 kV test voltage per EN 61140

Configuration	
Configuration options	DIP switch
Input	
Input signal type	Voltage; Current
Input signal (voltage)	±60 mV; 0 ... 60 mV; ±100 mV; 0 ... 100 mV; ±150 mV; 0 ... 150 mV; ±300 mV; 0 ... 300 mV; ±500 mV; 0 ... 500 mV; ±1 V; 0 ... 1 V; ±5 V; 0 ... 5 V; 1 ... 5 V; ±10 V; 0 ... 10 V; 2 ... 10 V; ±100 V; 0 ... 100 V; ±200 V; 0 ... 200 V
Input signal (current)	±0.3 mA; 0 ... 0.3 mA; ±1 mA; 0 ... 1 mA; ±5 mA; 0 ... 5 mA; ±10 mA; 0 ... 10 mA; ±20 mA; 0 ... 20 mA; 4 ... 20 mA; ±50 mA; 0 ... 50 mA; ±100 mA; 0 ... 100 mA
Input resistance (current input)	10 Ω (≥ 5 mA); 100 Ω (≤ 5 mA)
Input resistance (voltage input)	1 MΩ
Output	
Output signal type	Current; Voltage
Output signal (voltage)	±5 V; 0 ... 5 V; 1 ... 5 V; ±10 V; 0 ... 10 V; 2 ... 10 V
Output signal (current)	±10 mA; 0 ... 10 mA; 2 ... 10 mA; ±20 mA; 0 ... 20 mA; 4 ... 20 mA
Load impedance (voltage output)	≥ 2 kΩ
Load impedance (current output)	≤ 600 Ω
Signal Processing	
Limit frequency	100 Hz / 5 kHz (configurable via DIP switch)
Step response (typ.)	3.5 ms (100 Hz); 100 μs (5 kHz)
Measurement Error	
Transmission error (typ.)	≤ 0.08 % of upper-range value
Temperature coefficient	≤ 0.01%/K
Power Supply	
Power supply type	24 VDC
Nominal supply voltage U _s	24 VDC
Supply voltage range	±30 %
Power consumption at nominal supply voltage	≤ 40 mA
Safety and Protection	
Test voltage (input/output/supply)	3 kVAC; 50 Hz; 1 min
Line-to-neutral conductor voltage	200 VAC
Overvoltage category	II
Pollution degree	2
Insulation type (input/supply, analog output/relay output)	Reinforced insulation
Protection type	IP20
Connection Data	
Connection technology	Push-in CAGE CLAMP®
Solid conductor	0.08 ... 2.5 mm ² / 28 ... 14 AWG
Fine-stranded conductor	0.34 ... 2.5 mm ² / 22 ... 14 AWG
Strip length	9 ... 10 mm / 0.35 ... 0.39 inch
Geometric Data	
Width	6 mm / 0.236 inch
Height from upper-edge of DIN-rail	97.8 mm / 3.85 inch
Depth	94 mm / 3.701 inch
Mechanical Data	
Mounting type	DIN-35 rail
Material Data	
Weight	39.9 g

Isolation Amplifier; Configurable; with Zero/Span Adjustment

857 Series

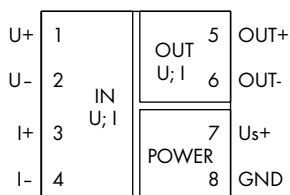

Isolation Amplifier; Bipolar current and voltage input signal; Bipolar current and voltage output signal; Zero/span adjustment; Supply voltage: 24 VDC; Module width: 6 mm

Item No.	Pack. Unit
857-409	1

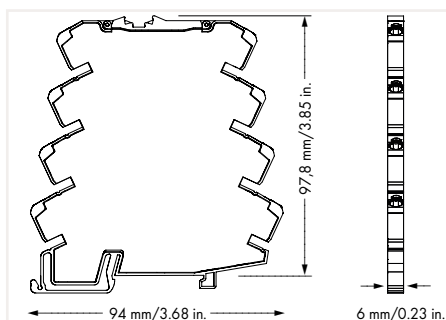

Short description:
WAGO's bipolar isolation amplifier converts, amplifies, filters, and electrically isolates standard unipolar/bipolar analog signals.

Features:

- Overload protection of current input via resettable fuse
- Zero/span adjustment across the entire measurement range
- Calibrated measurement range switching
- Unipolar/bipolar standard analog signals at both input/output
- Switchable limit frequency
- Safe 3-way isolation with 2.5 kV test voltage per EN 61140

Specialty Functions:



Configuration via:



Configuration	
Configuration options	DIP switch
Input	
Input signal type	Voltage; Current
Input signal (voltage)	±5 V; 0 ... 5 V; 1 ... 5 V; ±10 V; 0 ... 10 V; 2 ... 10 V
Input signal (current)	±10 mA; 0 ... 10 mA; 2 ... 10 mA; ±20 mA; 0 ... 20 mA; 4 ... 20 mA
Input resistance (current input)	≤ 50 Ω (approx.)
Input resistance (voltage input)	1 MΩ (approx.)
Input current (max.)	50 mA
Input voltage (max.)	32 V
Zero/span adjustment	±5 % of upper range value
Output	
Output signal type	Current; Voltage
Output signal (voltage)	±5 V; 0 ... 5 V; 1 ... 5 V; ±10 V; 0 ... 10 V; 2 ... 10 V
Output signal (current)	±10 mA; 0 ... 10 mA; 2 ... 10 mA; ±20 mA; 0 ... 20 mA; 4 ... 20 mA
Load impedance (voltage output)	≥ 2 kΩ
Load impedance (current output)	≤ 600 Ω
Residual ripple	≤ 10 mV (rms)
Signal Processing	
Limit frequency	100 Hz / 5 kHz (configurable via DIP switch)
Step response (typ.)	3.5 ms (100 Hz); 60 μs (5 kHz)
Measurement Error	
Transmission error (typ.)	≤ 0.1 % of upper-range value
Temperature coefficient	≤ 0.01%/K
Power Supply	
Power supply type	24 VDC
Nominal supply voltage U _s	24 VDC
Supply voltage range	±30 %
Power consumption at nominal supply voltage	≤ 25 mA
Safety and Protection	
Test voltage (input/output/supply)	2.5 kVAC; 50 Hz; 1 min
Protection type	IP20
Connection Data	
Connection technology	Push-in CAGE CLAMP®
Solid conductor	0.08 ... 2.5 mm ² / 28 ... 14 AWG
Fine-stranded conductor	0.34 ... 2.5 mm ² / 22 ... 14 AWG
Strip length	9 ... 10 mm / 0.35 ... 0.39 inch
Geometric Data	
Width	6 mm / 0.236 inch
Height from upper-edge of DIN-rail	97.8 mm / 3.85 inch
Depth	94 mm / 3.701 inch
Mechanical Data	
Mounting type	DIN-35 rail
Material Data	
Weight	38.4 g
Environmental Requirements	
Surrounding air temperature (operation)	-25 ... +70 °C
Surrounding air temperature (storage)	-40 ... +85 °C
Relative humidity	5 ... 95 % (no condensation permissible)
Operating altitude (max.)	2000 m
Standards and Specifications	
Conformity marking	CE
EMC immunity to interference	EN 61000-6-2
EMC emission of interference	EN 61000-6-3

857-409

DIP Switch Adjustability

● = ON Default

DIP Switch S1 (4-fold)				DIP Switch S2 (6-fold)							
Input Signal				Output Signal					Max. Operating Frequency		
1	2	3	4	1	2	3	4	5	6		
●								●		±20 mA	5 kHz
●	●						●	●		±10 mA	100 Hz
●				●	●	●	●	●		±10 V	
●	●			●	●	●	●			±5 V	
										0 ... 20 mA	
		●						●		4 ... 20 mA	
	●					●				0 ... 10 mA	
	●	●				●	●			2 ... 10 mA	
				●	●					0 ... 10 V	
		●		●	●			●		2 ... 10 V	
	●			●	●	●				0 ... 5 V	
	●	●		●	●	●		●		1 ... 5 V	

Isolation Amplifier; Pre-Configured; Current Input; Current Output 857 Series

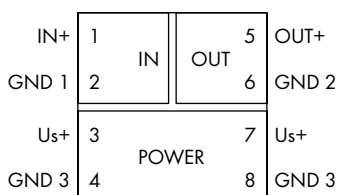

Isolation Amplifier; Current input signal: 0 (4) ... 20 mA;
Current output signal: 0 (4) ... 20 mA; Supply voltage: 24 VDC;
Module width: 6 mm wide

Item No.	Pack. Unit
857-411	1

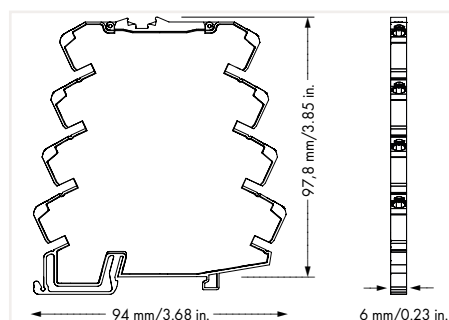

Short description:

WAGO's pre-configured isolation amplifier converts, amplifies, filters, and electrically isolates standard analog signals.

Features:

- Input/output: current or voltage signal
- Safe 3-way isolation with 2.5 kV test voltage per EN 61140

Configuration	
Configuration options	Pre-configured
Input	
Input signal type	Current
Input signal (current)	0 ... 20 mA; 4 ... 20 mA
Input resistance (current input)	≤ 50 Ω
Input current (max.)	50 mA
Output	
Output signal type	Current
Output signal (current)	0 ... 20 mA; 4 ... 20 mA
Load impedance (current output)	≤ 600 Ω
Signal Processing	
Limit frequency	100 Hz
Step response (typ.)	3.5 ms
Measurement Error	
Transmission error (typ.)	≤ 0.1 % of upper-range value
Temperature coefficient	≤ 0.01%/K
Power Supply	
Power supply type	24 VDC
Nominal supply voltage U_s	24 VDC
Supply voltage range	±30 %
Power consumption at nominal supply voltage	≤ 25 mA
Safety and Protection	
Test voltage (input/output/supply)	2.5 kVAC; 50 Hz; 1 min
Protection type	IP20
Connection Data	
Connection technology	Push-in CAGE CLAMP®
Solid conductor	0.08 ... 2.5 mm ² / 28 ... 14 AWG
Fine-stranded conductor	0.34 ... 2.5 mm ² / 22 ... 14 AWG
Strip length	9 ... 10 mm / 0.35 ... 0.39 inch
Geometric Data	
Width	6 mm / 0.236 inch
Height from upper-edge of DIN-rail	97.8 mm / 3.85 inch
Depth	94 mm / 3.701 inch
Mechanical Data	
Mounting type	DIN-35 rail
Material Data	
Weight	36.1 g
Environmental Requirements	
Surrounding air temperature (operation)	-25 ... +70 °C
Surrounding air temperature (storage)	-40 ... +85 °C
Relative humidity	5 ... 95 % (no condensation permissible)
Operating altitude (max.)	2000 m
Standards and Specifications	
Conformity marking	CE
EMC immunity to interference	EN 61000-6-2
EMC emission of interference	EN 61000-6-4

Isolation Amplifier; Pre-Configured; Voltage Input; Voltage Output

857 Series

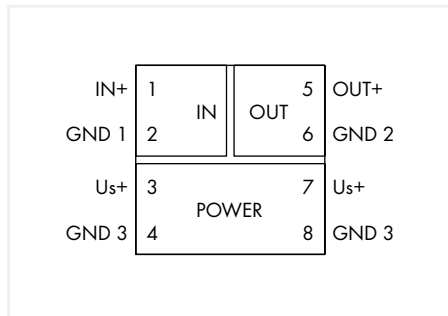

Isolation Amplifier; Voltage input signal: 0 (2) ... 10 V;
Voltage output signal: 0 (2) ... 10 V; Supply voltage: 24 VDC;
Module width: 6 mm

Item No.	Pack. Unit
857-412	1

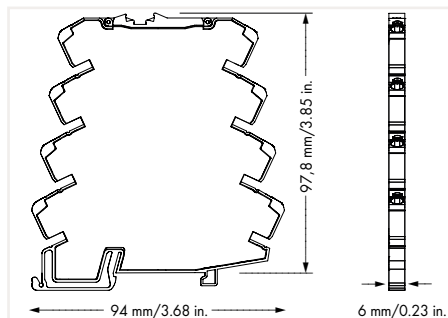

Short description:

WAGO's pre-configured isolation amplifier converts, amplifies, filters, and electrically isolates standard analog signals.

Features:

- Input/output: current or voltage signal
- Safe 3-way isolation with 2.5 kV test voltage per EN 61140

Configuration	
Configuration options	Pre-configured
Input	
Input signal type	Voltage
Input signal (voltage)	0 ... 10 V; 2 ... 10 V
Input resistance (voltage input)	≥ 100 kΩ
Input voltage (max.)	30 V
Output	
Output signal type	Voltage
Output signal (voltage)	0 ... 10 V; 2 ... 10 V
Load impedance (voltage output)	≥ 2 kΩ
Signal Processing	
Limit frequency	100 Hz
Step response (typ.)	3.5 ms
Measurement Error	
Transmission error (typ.)	≤ 0.1 % of upper-range value
Temperature coefficient	≤ 0.01%/K
Power Supply	
Power supply type	24 VDC
Nominal supply voltage U_s	24 VDC
Supply voltage range	±30 %
Power consumption at nominal supply voltage	≤ 25 mA
Safety and Protection	
Test voltage (input/output/supply)	2.5 kVAC; 50 Hz; 1 min
Protection type	IP20
Connection Data	
Connection technology	Push-in CAGE CLAMP®
Solid conductor	0.08 ... 2.5 mm ² / 28 ... 14 AWG
Fine-stranded conductor	0.34 ... 2.5 mm ² / 22 ... 14 AWG
Strip length	9 ... 10 mm / 0.35 ... 0.39 inch
Geometric Data	
Width	6 mm / 0.236 inch
Height from upper-edge of DIN-rail	97.8 mm / 3.85 inch
Depth	94 mm / 3.701 inch
Mechanical Data	
Mounting type	DIN-35 rail
Material Data	
Weight	35.6 g
Environmental Requirements	
Surrounding air temperature (operation)	-25 ... +70 °C
Surrounding air temperature (storage)	-40 ... +85 °C
Relative humidity	5 ... 95 % (no condensation permissible)
Operating altitude (max.)	2000 m
Standards and Specifications	
Conformity marking	CE
EMC immunity to interference	EN 61000-6-2
EMC emission of interference	EN 61000-6-4

Isolation Amplifier; Pre-Configured; Voltage Input; Current Output 857 Series



3

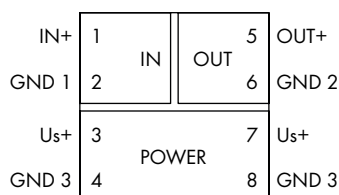

Isolation Amplifier; Voltage input signal: 0 ... 10 V; Supply voltage: 24 VDC; Module width: 6 mm

Output Signal	Item No.	Pack. Unit
0 ... 20 mA	857-413	1
4 ... 20 mA	857-414	1

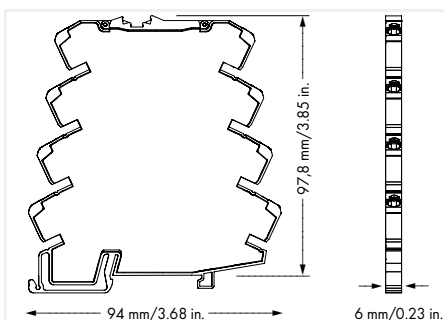

Short description:

WAGO's pre-configured isolation amplifier converts, amplifies, filters, and electrically isolates standard analog signals.

Features:

- Input/output: current or voltage signal
- Safe 3-way isolation with 2.5 kV test voltage per EN 61140

Configuration	
Configuration options	Pre-configured
Input	
Input signal type	Voltage
Input signal (voltage)	0 ... 10 V
Input resistance (voltage input)	≥ 100 kΩ
Input voltage (max.)	30 V
Output	
Output signal type	Current
Load impedance (current output)	≤ 600 Ω
Signal Processing	
Limit frequency	100 Hz
Step response (typ.)	3.5 ms
Measurement Error	
Transmission error (typ.)	≤ 0.1 % of upper-range value
Temperature coefficient	≤ 0.01%/K
Power Supply	
Power supply type	24 VDC
Nominal supply voltage U_s	24 VDC
Supply voltage range	±30 %
Power consumption at nominal supply voltage	≤ 25 mA
Safety and Protection	
Test voltage (input/output/supply)	2.5 kVAC; 50 Hz; 1 min
Protection type	IP20
Connection Data	
Connection technology	Push-in CAGE CLAMP®
Solid conductor	0.08 ... 2.5 mm ² / 28 ... 14 AWG
Fine-stranded conductor	0.34 ... 2.5 mm ² / 22 ... 14 AWG
Strip length	9 ... 10 mm / 0.35 ... 0.39 inch
Geometric Data	
Width	6 mm / 0.236 inch
Height from upper-edge of DIN-rail	97.8 mm / 3.85 inch
Depth	94 mm / 3.701 inch
Mechanical Data	
Mounting type	DIN-35 rail
Material Data	
Weight	36.01 g
Environmental Requirements	
Surrounding air temperature (operation)	-25 ... +70 °C
Surrounding air temperature (storage)	-40 ... +85 °C
Relative humidity	5 ... 95 % (no condensation permissible)
Operating altitude (max.)	2000 m
Standards and Specifications	
Conformity marking	CE
EMC immunity to interference	EN 61000-6-2
EMC emission of interference	EN 61000-6-4

Isolation Amplifier; Pre-Configured; Current Input; Voltage Output

857 Series

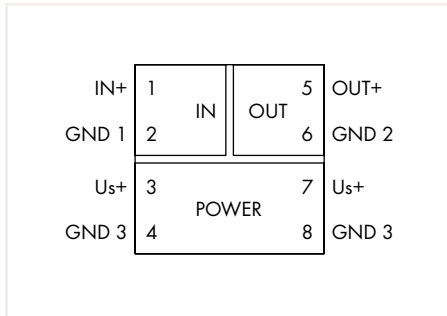

Isolation Amplifier; Voltage output signal: 0 ... 10 V;
Supply voltage: 24 VDC; Module width: 6 mm

Input Signal	Item No.	Pack. Unit
0 ... 20 mA	857-415	1
4 ... 20 mA	857-416	1

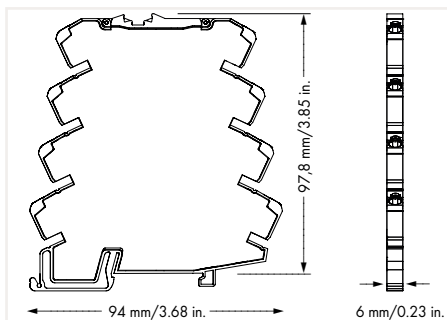

Short description:

WAGO's pre-configured isolation amplifier converts, amplifies, filters, and electrically isolates standard analog signals.

Features:

- Input/output: current or voltage signal
- Safe 3-way isolation with 2.5 kV test voltage per EN 61140

Configuration	
Configuration options	Pre-configured
Input	
Input signal type	Current
Input resistance (current input)	≤ 50 Ω
Input current (max.)	50 mA
Output	
Output signal type	Voltage
Output signal (voltage)	0 ... 10 V
Load impedance (voltage output)	≥ 2 kΩ
Signal Processing	
Limit frequency	100 Hz
Step response (typ.)	3.5 ms
Measurement Error	
Transmission error (typ.)	≤ 0.1 % of upper-range value
Temperature coefficient	≤ 0.01%/K
Power Supply	
Power supply type	24 VDC
Nominal supply voltage U_s	24 VDC
Supply voltage range	±30 %
Power consumption at nominal supply voltage	≤ 25 mA
Safety and Protection	
Test voltage (input/output/supply)	2.5 kVAC; 50 Hz; 1 min
Protection type	IP20
Connection Data	
Connection technology	Push-in CAGE CLAMP®
Solid conductor	0.08 ... 2.5 mm ² / 28 ... 14 AWG
Fine-stranded conductor	0.34 ... 2.5 mm ² / 22 ... 14 AWG
Strip length	9 ... 10 mm / 0.35 ... 0.39 inch
Geometric Data	
Width	6 mm / 0.236 inch
Height from upper-edge of DIN-rail	97.8 mm / 3.85 inch
Depth	94 mm / 3.701 inch
Mechanical Data	
Mounting type	DIN-35 rail
Material Data	
Weight	35.31 g
Environmental Requirements	
Surrounding air temperature (operation)	-25 ... +70 °C
Surrounding air temperature (storage)	-40 ... +85 °C
Relative humidity	5 ... 95 % (no condensation permissible)
Operating altitude (max.)	2000 m
Standards and Specifications	
Conformity marking	CE
EMC immunity to interference	EN 61000-6-2
EMC emission of interference	EN 61000-6-4

Isolation Amplifier; Configurable; with Current and Voltage Output 857 Series

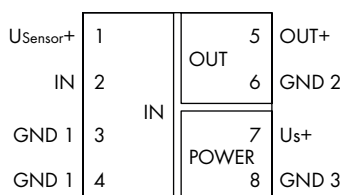

Isolation Amplifier; Current input signal; Current and voltage output signal; Supply voltage: 24 VDC; Module width: 6 mm

Item No.	Pack. Unit
857-420	1

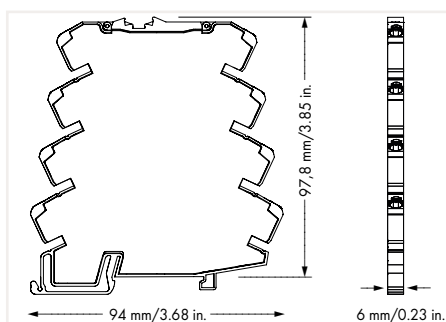

Short description:

WAGO's repeater power supply provides the power required for 2- or 3-wire field transmitters, and electrically isolates analog signals.

Features:

- Power supply to SMART transmitters
- Calibrated measurement range switching
- Safe 3-way isolation with 2.5 kV test voltage per EN 61140

Configuration via:



Configuration	
Configuration options	DIP switch
Input	
Input signal type	Current
Input signal (current)	0 ... 20 mA; 4 ... 20 mA
Input resistance (current input)	≤ 50 Ω
Input current (max.)	50 mA
Sensor supply	U _v = 18 V; 30 mA
Output	
Output signal type	Current; Voltage
Output signal (voltage)	0 ... 5 V; 1 ... 5 V; 0 ... 10 V; 2 ... 10 V (calibrated switching)
Output signal (current)	0 ... 20 mA; 4 ... 20 mA (calibrated switching)
Load impedance (voltage output)	≥ 2 kΩ
Load impedance (current output)	≤ 600 Ω
Offset	≤ 20 μA
Residual ripple	≤ 10 mV (rms)
Signal Processing	
Limit frequency	100 Hz
Step response (typ.)	3.5 ms
Measurement Error	
Transmission error (typ.)	≤ 0.1 % of upper-range value
Temperature coefficient	≤ 0.01%/K
Power Supply	
Power supply type	24 VDC
Nominal supply voltage U _s	24 VDC
Supply voltage range	±30 %
Power consumption at nominal supply voltage	≤ 45 mA
Safety and Protection	
Test voltage (input/output/supply)	2.5 kVAC; 50 Hz; 1 min
Protection type	IP20
Connection Data	
Connection technology	Push-in CAGE CLAMP®
Solid conductor	0.08 ... 2.5 mm ² / 28 ... 14 AWG
Fine-stranded conductor	0.34 ... 2.5 mm ² / 22 ... 14 AWG
Strip length	9 ... 10 mm / 0.35 ... 0.39 inch
Geometric Data	
Width	6 mm / 0.236 inch
Height from upper-edge of DIN-rail	97.8 mm / 3.85 inch
Depth	94 mm / 3.701 inch
Mechanical Data	
Mounting type	DIN-35 rail
Material Data	
Weight	37 g
Environmental Requirements	
Surrounding air temperature (operation)	-25 ... +70 °C
Surrounding air temperature (storage)	-40 ... +85 °C
Relative humidity	5 ... 95 % (no condensation permissible)
Operating altitude (max.)	2000 m
Standards and Specifications	
Conformity marking	CE

857-420

DIP Switch Adjustability

● = ON Default

DIP Switch S1 (6-fold)

1	2	3	4	5	6	Input Signal	Output Signal
					n.c.	0 ... 20 mA	0 ... 20 mA
			●		n.c.	0 ... 20 mA	4 ... 20 mA
●	●				n.c.	0 ... 20 mA	0 ... 10 V
●	●		●		n.c.	0 ... 20 mA	2 ... 10 V
●	●	●			n.c.	0 ... 20 mA	0 ... 5 V
●	●	●	●		n.c.	0 ... 20 mA	1 ... 5 V
				●	n.c.	4 ... 20 mA	0 ... 20 mA
					n.c.	4 ... 20 mA	4 ... 20 mA
●	●			●	n.c.	4 ... 20 mA	0 ... 10 V
●	●				n.c.	4 ... 20 mA	2 ... 10 V
●	●	●		●	n.c.	4 ... 20 mA	0 ... 5 V
●	●	●			n.c.	4 ... 20 mA	1 ... 5 V

Isolation Amplifier; Configurable; with 2 Current Outputs 857 Series

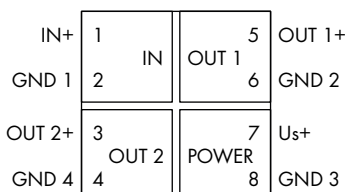

Isolation Amplifier; Current and voltage input signal;
2x current output signal; Supply voltage: 24 VDC;
Module width: 6 mm

Item No.	Pack. Unit
857-423	1

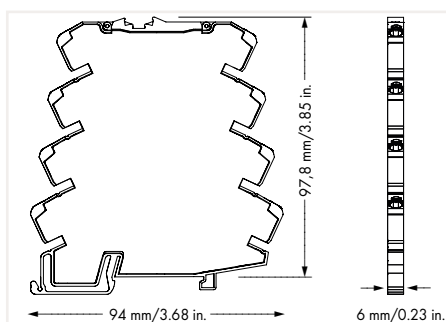

Short description:

WAGO's signal splitter converts, amplifies, filters, and electrically isolates standard analog signals.

Features:

- Two configurable current outputs
- Calibrated measurement range switching
- Switchable limit frequency
- Safe 4-way isolation with 2.5 kV test voltage per EN 61140

Configuration via:



Configuration	
Configuration options	DIP switch
Input	
Input signal type	Voltage; Current
Input signal (voltage)	0 ... 5 V; 1 ... 5 V; 0 ... 10 V; 2 ... 10 V (calibrated switching)
Input signal (current)	0 ... 20 mA; 4 ... 20 mA (calibrated switching)
Input resistance (current input)	≤ 50 Ω
Input resistance (voltage input)	≥ 100 kΩ
Output	
Output signal type	Current
Output signal (current)	0 ... 20 mA; 4 ... 20 mA (calibrated switching)
Load impedance (current output)	≤ 300 Ω
Signal Processing	
Limit frequency	100 Hz / 1 kHz (configurable via DIP switch)
Step response (typ.)	3.5 ms (100 Hz); 300 μs (1 kHz)
Measurement Error	
Transmission error (typ.)	≤ 0.1 % of upper-range value
Transmission error (max.)	≤ 0.2 % of upper-range value
Temperature coefficient	≤ 0.01%/K
Power Supply	
Power supply type	24 VDC
Nominal supply voltage U_s	24 VDC
Supply voltage range	±30 %
Power consumption at nominal supply voltage	≤ 35 mA
Safety and Protection	
Test voltage (input/output/supply)	2.5 kVAC; 50 Hz; 1 min
Protection type	IP20
Connection Data	
Connection technology	Push-in CAGE CLAMP®
Solid conductor	0.08 ... 2.5 mm ² / 28 ... 14 AWG
Fine-stranded conductor	0.34 ... 2.5 mm ² / 22 ... 14 AWG
Strip length	9 ... 10 mm / 0.35 ... 0.39 inch
Geometric Data	
Width	6 mm / 0.236 inch
Height from upper-edge of DIN-rail	97.8 mm / 3.85 inch
Depth	94 mm / 3.701 inch
Mechanical Data	
Mounting type	DIN-35 rail
Material Data	
Weight	40.6 g
Environmental Requirements	
Surrounding air temperature (operation)	-25 ... +70 °C
Surrounding air temperature (storage)	-40 ... +85 °C
Relative humidity	5 ... 95 % (no condensation permissible)
Operating altitude (max.)	2000 m
Standards and Specifications	
Conformity marking	CE
EMC immunity to interference	EN 61000-6-2
EMC emission of interference	EN 61000-6-4

857-423

DIP Switch Adjustability

● = ON Default

DIP Switch S1 (6-fold)

Input Signal			Max. Operating Frequency	Output Signal 1		Output Signal 2	
1	2	3	4	5	6		
●			0 ... 20 mA	1 kHz	0 ... 20 mA		0 ... 20 mA
●		●	4 ... 20 mA	100 Hz	4 ... 20 mA	●	4 ... 20 mA
	●		0 ... 10 V				
	●	●	2 ... 10 V				
			0 ... 5 V				
		●	1 ... 5 V				

Isolation Amplifier; Configurable; with Current and Voltage Output

857 Series

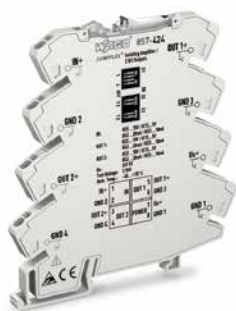

3

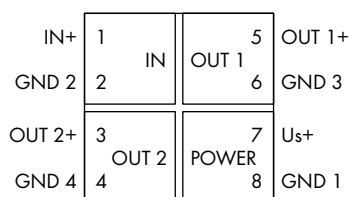

Isolation Amplifier; Current and voltage input signal; Current and voltage output signal; Supply voltage: 24 VDC; Module width: 6 mm

Item No.	Pack. Unit
857-424	1

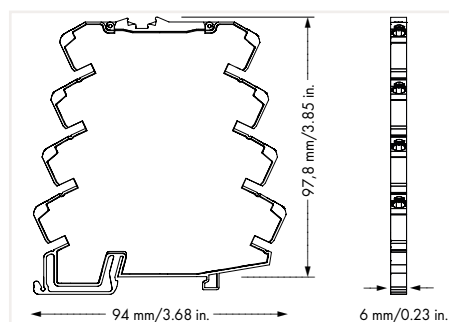

Short description:

WAGO's signal splitter converts, amplifies, filters, and electrically isolates standard analog signals. In addition, the input signal is split into two separate outputs.

Features:

- Two configurable voltage/current outputs
- Switchable limit frequency
- Safe 4-way isolation with 3 kV test voltage per EN 61010-1

Configuration via:



Configuration	
Configuration options	DIP switch
Input	
Input signal type	Voltage; Current
Input signal (voltage)	0 ... 5 V; 1 ... 5 V; 0 ... 1 V; 0 ... 10 V; 2 ... 10 V
Input signal (current)	0 ... 10 mA; 2 ... 10 mA; 0 ... 20 mA; 4 ... 20 mA
Input resistance (current input)	≤ 50 Ω
Input resistance (voltage input)	≥ 100 kΩ
Input current (max.)	50 mA
Input voltage (max.)	30 V
Output	
Output signal type	Voltage; Current
Output signal (voltage)	0 ... 10 V; 2 ... 10 V (calibrated switching)
Output signal (current)	0 ... 10 mA; 2 ... 10 mA; 0 ... 20 mA; 4 ... 20 mA (calibrated switching)
Load impedance (voltage output)	≥ 2 kΩ
Load impedance (current output)	≤ 600 Ω
Signal Processing	
Limit frequency	100 Hz / 1 kHz (configurable via DIP switch)
Step response (typ.)	3.5 ms (100 Hz); 300 μs (1 kHz)
Measurement Error	
Transmission error (typ.)	≤ 0.1 % of upper-range value
Temperature coefficient	≤ 0.01%/K
Power Supply	
Power supply type	24 VDC
Nominal supply voltage U _S	24 VDC
Supply voltage range	-60 ... +30 %
Power consumption at nominal supply voltage	≤ 35 mA (typ.); ≤ 250 mA max.)
Safety and Protection	
Measurement category per EN/UL 61010-2-030	CAT II (input)
Protection type	IP20
Test voltage (input/analog output 1/analog output 2/supply)	3 kVAC; 50 ... 60 Hz; 1 min
Insulation parameters per EN/UL 61010-1	
Line-to-neutral conductor voltage (AC) max.	300 V
Overvoltage category	II
Pollution degree	2
Insulation type (input/analog output 1/analog output 2/supply)	Reinforced insulation
Connection Data	
Connection technology	Push-in CAGE CLAMP®
Solid conductor	0.08 ... 2.5 mm ² / 28 ... 14 AWG
Fine-stranded conductor	0.34 ... 2.5 mm ² / 22 ... 14 AWG
Strip length	9 ... 10 mm / 0.35 ... 0.39 inch
Cable type	Shielded cable
Geometric Data	
Width	6 mm / 0.236 inch
Height from upper-edge of DIN-rail	97.8 mm / 3.85 inch
Depth	94 mm / 3.701 inch
Mechanical Data	
Mounting type	DIN-35 rail
Material Data	
Weight	41.5 g

Environmental Requirements	
Surrounding air temperature (operation)	-40 ... 70 °C (for single module; -40 ... +60 °C for module assembly)
Surrounding air temperature (storage)	-40 ... 85 °C
Temperature range of the connecting cable according to EN 61010-2-201	$\geq (T_{\text{surrounding air}} + 10 \text{ K})$
Temperature range of connecting cable per UL 61010-2-201 (min.)	90 °C
Relative humidity	5 ... 95 % (no condensation permissible)
Operating altitude (max.)	2000 m
Standards and Specifications	
Conformity marking	CE
EMC immunity to interference	EN 61000-6-2; EN 61326-1; EN 50121-3-2
EMC emission of interference	EN 61000-6-3; EN 61326-1; EN 50121-3-2
Standards/specifications	EN 61010-1; EN 61373

857-424

DIP Switch Adjustability

● = ON Default

DIP Switch S1 (4 positions)

Input Signal			Max. Operating Frequency	
1	2	3	4	
●				> 1 kHz
●		●	●	100 Hz
●	●			
●	●	●		
		●		
	●			
	●	●		

DIP Switch S2 (2 positions)

Output Signal 1	
1	2
●	
	●
●	●

DIP Switch S3 (2 positions)

Output Signal 2	
1	2
●	
	●
●	●

Loop-Powered Isolation Amplifier 857 Series

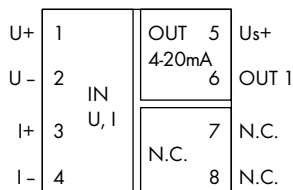

Loop-Powered Isolation Amplifier; Bipolar current and voltage input signal; Current output signal; Power via input; Module width: 6 mm

Item No.	Pack. Unit
857-450	1

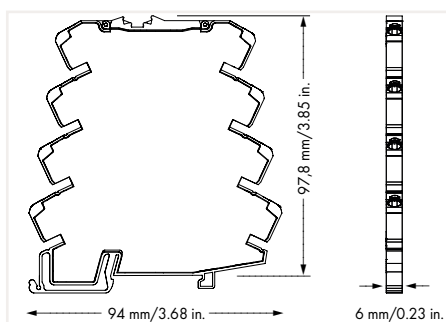

Short description:

WAGO's loop-powered isolation amplifier converts, amplifies, filters, and electrically isolates standard unipolar/bipolar analog signals.

Features:

- No additional supply voltage required
- Zero/span adjustment
- Standard unipolar/bipolar analog signals at input
- Calibrated measurement range switching
- Switchable limit frequency
- Safe 2-way isolation with 2.5 kV test voltage per EN 61140

Specialty Functions:



Configuration via:



Configuration	
Configuration options	DIP switch
Input	
Input signal type	Voltage; Current
Input signal (voltage)	± 1 V; 0 ... 1 V; ± 2 V; 0 ... 2 V; ± 5 V; 0 ... 5 V; 1 ... 5 V; ± 10 V; 0 ... 10 V; 2 ... 10 V; ± 20 V
Input signal (current)	± 5 mA; 0 ... 5 mA; ± 10 mA; 0 ... 10 mA; 2 ... 10 mA; ± 20 mA; 0 ... 20 mA; 4 ... 20 mA
Input resistance (current input)	$\leq 50 \Omega$
Input resistance (voltage input)	≥ 1 M Ω
Input current (max.)	50 mA
Input voltage (max.)	30 V
Zero/span adjustment	± 5 % of upper range value
Output	
Output signal type	Current
Output signal (current)	4 ... 20 mA
Load impedance (current output)	$\leq 600 \Omega$
Signal Processing	
Limit frequency	100 Hz / 30 Hz (configurable via DIP switch)
Step response (typ.)	3.5 ms
Measurement Error	
Transmission error (typ.)	≤ 0.1 % of upper-range value
Temperature coefficient	≤ 0.01 %/K
Power Supply	
Power supply type	loop-powered (via output)
Supply voltage	8 ... 30 VDC (power derived from the output circuit)
Safety and Protection	
Test voltage (input/output/supply)	2.5 kVAC; 50 Hz; 1 min
Protection type	IP20
Connection Data	
Connection technology	Push-in CAGE CLAMP®
Solid conductor	0.08 ... 2.5 mm ² / 28 ... 14 AWG
Fine-stranded conductor	0.34 ... 2.5 mm ² / 22 ... 14 AWG
Strip length	9 ... 10 mm / 0.35 ... 0.39 inch
Geometric Data	
Width	6 mm / 0.236 inch
Height from upper-edge of DIN-rail	97.8 mm / 3.85 inch
Depth	94 mm / 3.701 inch
Mechanical Data	
Mounting type	DIN-35 rail
Material Data	
Weight	37.9 g
Environmental Requirements	
Surrounding air temperature (operation)	-25 ... +70 °C
Surrounding air temperature (storage)	-40 ... +85 °C
Relative humidity	5 ... 95 % (no condensation permissible)
Operating altitude (max.)	2000 m
Standards and Specifications	
Conformity marking	CE
EMC immunity to interference	EN 61000-6-2
EMC emission of interference	EN 61000-6-3

857-450

DIP Switch Adjustability

● = ON Default

DIP switch (6 positions)

Input Signal					Output Signal	Max. Operating Frequency		
1	2	3	4	5		6		
					4 ... 20 mA	4 ... 20 mA		
●		●	●		0 ... 20 mA		●	100 Hz
●		●	●	●	±20 mA			30 Hz
●		●			2 ... 10 mA			
●			●		0 ... 10 mA			
●			●	●	±10 mA			
●					0 ... 5 mA			
●				●	±5 mA			
	●	●	●		0 ... 20 V			
	●	●	●	●	±20 V			
	●	●			2 ... 10 V			
	●		●		0 ... 10 V			
	●		●	●	±10 V			
	●				1 ... 5 V			
		●	●		0 ... 5 V			
		●	●	●	±5 V			
		●			0 ... 2 V			
		●		●	±2 V			
			●		0 ... 1 V			
			●	●	±1 V			

Passive Isolator; 1-Channel 857 Series



IN+	1	IN	5	OUT+
GND 1	2		6	GND 2
N.C.	3		7	N.C.
N.C.	4		8	N.C.

Passive Isolator; 1-channel; Current input signal; Current output signal; Power via input; Module width: 6 mm wide

Item No.	Pack. Unit
857-451	1

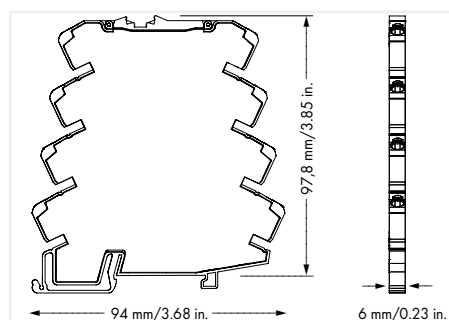

Short description:

WAGO's passive isolator (1-channel) electrically isolates and filters 0(4)–20 mA standard analog signals, while drawing power for signal transmission from the input circuit. The connected sensor supplies the passive isolator with the required power to energize the connected load.

Features:

- No additional supply voltage required
- Safe 2-way isolation with 2.5 kV test voltage per EN 61140

Configuration	
Configuration options	Pre-configured
Input	
Input signal type	Current
Input signal (current)	0 ... 20 mA; 4 ... 20 mA
Voltage drop at input	≤ 2.5 V at 20 mA (output)
Input current (max.)	40 mA
Input voltage (max.)	20 V
Response threshold	200 µA
Output	
Output signal type	Current
Output signal (current)	0 ... 20 mA; 4 ... 20 mA
Load impedance (current output)	≤ 600 Ω (temperature range restrictions may occur)
Signal Processing	
Limit frequency	100 Hz
Step response (typ.)	3.5 ms
Measurement Error	
Transmission error (typ.)	≤ 0.1 % of upper-range value
Load error	≤ 0.05 % (of upper-range value; per 100 Ω load)
Temperature coefficient	≤ 0.01 %/K
Supply	
Power supply type	passive (via input)
Safety and Protection	
Measurement category per EN/UL 61010-2-030	CAT II (input)
Line-to-neutral conductor voltage	AC 300 V
Overvoltage category	II
Pollution degree	2
Protection type	IP20
Test voltage	
Test voltage (input/output)	AC 3 kV; 50 Hz; 1 min
Test voltage (input/output) AC	3000 V
Test voltage (input/output) duration	1 min
Test voltage (input/output) frequency	50 Hz
Insulation parameters per EN/UL 61010-1	
Insulation type (input/analog output)	Reinforced insulation
Connection Data	
Connection technology	Push-in CAGE CLAMP®
Solid conductor	0.08 ... 2.5 mm² / 28 ... 14 AWG
Fine-stranded conductor	0.34 ... 2.5 mm² / 22 ... 14 AWG
Strip length	9 ... 10 mm / 0.35 ... 0.39 inch
Cable type	Shielded cable
Geometric Data	
Width	6 mm / 0.236 inch
Height from upper-edge of DIN-rail	97.8 mm / 3.85 inch
Depth	94 mm / 3.701 inch
Mechanical Data	
Mounting type	DIN-35 rail
Material Data	
Weight	34.2 g
Environmental Requirements	
Surrounding air temperature (operation)	-25 ... +70 °C
Surrounding air temperature (storage)	-40 ... +85 °C
Temperature range of the connecting cable according to EN 61010-2-201	≥ (T _{surrounding air} + 15 K)
Temperature range of connecting cable per UL 61010-2-201 (min.)	85 °C
Relative humidity	5 ... 95 % (no condensation permissible)
Operating altitude (max.)	2000 m
Standards and Specifications	
Conformity marking	CE
EMC immunity to interference	EN 61000-6-2
EMC emission of interference	EN 61000-6-4

Passive Isolator; 2-Channel 857 Series

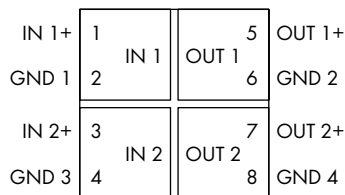

Passive Isolator; 2-channel; Current input signal;
2 x Current output signal; Power via input; Module width:
6 mm wide

Item No.	Pack. Unit
857-452	1

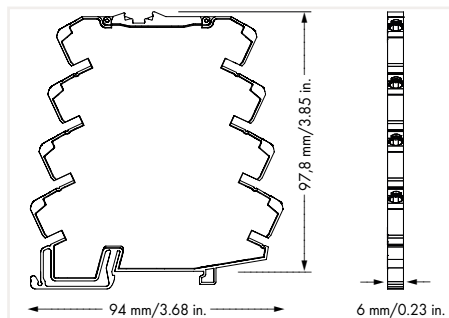

Short description:

WAGO's passive isolator (2-channel) electrically isolates and filters 0(4)–20 mA standard analog signals, while drawing power for signal transmission from the input circuit. The connected sensor supplies the passive isolator with the required power to energize the connected load.

Features:

- No additional supply voltage required
- Safe 2-way isolation with 2.5 kV test voltage per EN 61140

Configuration	
Configuration options	Pre-configured
Input	
Input signal type	Current
Input signal (current)	0 ... 20 mA; 4 ... 20 mA
Voltage drop at input	≤ 2.5 V at 20 mA (output)
Input current (max.)	40 mA
Input voltage (max.)	20 V
Response threshold	200 µA
Output	
Output signal type	Current
Output signal (current)	0 ... 20 mA; 4 ... 20 mA
Load impedance (current output)	≤ 600 Ω (temperature range restrictions may occur)
Signal Processing	
Limit frequency	100 Hz
Step response (typ.)	3.5 ms
Measurement Error	
Transmission error (typ.)	≤ 0.1 % of upper-range value
Load error	≤ 0.05 % (of upper-range value; per 100 Ω load)
Temperature coefficient	≤ 0.01 %/K
Supply	
Power supply type	passive (via input)
Safety and Protection	
Measurement category per EN/UL 61010-2-030	CAT II (input)
Line-to-neutral conductor voltage	AC 300 V
Overvoltage category	II
Pollution degree	2
Protection type	IP20
Test voltage	
Test voltage (input/output)	AC 3 kV; 50 Hz; 1 min
Test voltage (input/output) AC	3000 V
Test voltage (input/output) duration	1 min
Test voltage (input/output) frequency	50 Hz
Insulation parameters per EN/UL 61010-1	
Insulation type (input/analog output)	Reinforced insulation
Connection Data	
Connection technology	Push-in CAGE CLAMP®
Solid conductor	0.08 ... 2.5 mm ² / 28 ... 14 AWG
Fine-stranded conductor	0.34 ... 2.5 mm ² / 22 ... 14 AWG
Strip length	9 ... 10 mm / 0.35 ... 0.39 inch
Cable type	Shielded cable
Geometric Data	
Width	6 mm / 0.236 inch
Height from upper-edge of DIN-rail	97.8 mm / 3.85 inch
Depth	94 mm / 3.701 inch
Mechanical Data	
Mounting type	DIN-35 rail
Material Data	
Weight	62 g
Environmental Requirements	
Surrounding air temperature (operation)	-25 ... +70 °C
Surrounding air temperature (storage)	-40 ... +85 °C
Temperature range of the connecting cable according to EN 61010-2-201	≥ (T _{surrounding air} + 15 K)
Temperature range of connecting cable per UL 61010-2-201 (min.)	85 °C
Relative humidity	5 ... 95 % (no condensation permissible)
Operating altitude (max.)	2000 m
Standards and Specifications	
Conformity marking	CE
EMC immunity to interference	EN 61000-6-2
EMC emission of interference	EN 61000-6-4

Current Signal Conditioner; Configurable; with Digital and Relay Output

2857 Series

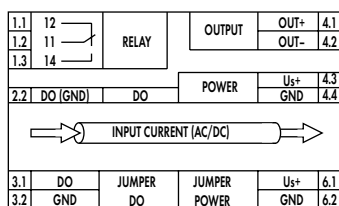

Current Signal Conditioner; Current input signal: 100 A AC/DC; Current and voltage output signal; Digital and relay output; Supply voltage: 24 VDC; Module width: 6 mm

	Item No.	Pack. Unit
	2857-550	1

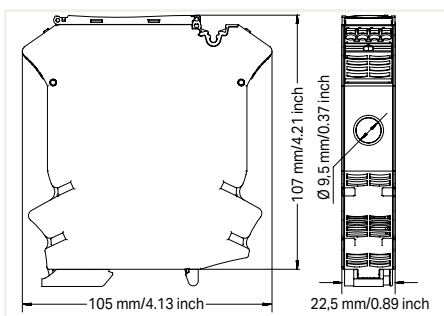

Short description:

WAGO's current signal conditioner measures AC/DC currents up to 100 A and converts the measured current into a standard analog signal at the output.

Features:

- Both digital signal output and relay with changeover contact react to configured measurement range limits (on/off switching delay and threshold value switch function can be configured with up to two threshold values)
- Clipping capability provides analog signal limitation to output end values
- Adjustable software filter
- Input/output response simulation via configuration display
- Safe 3-way isolation with 3 kV test voltage per EN 61010-1

Note:

Additional setting options via interface configuration software/app

Configuration

Configuration options	DIP switch; Interface configuration software; Interface configuration app; Configuration display
-----------------------	--

Input

Input signal type	Current
Input signal (current)	0.5 ... 100 AAC; -100 ... +100 ADC
Frequency range	15 ... 1000 Hz
Input current (max.)	100 A AC/DC
Response threshold	500 mA (AC); 250 mA (DC)
Resolution	10 mA

Output

Output signal type	Current; Voltage
Output signal (voltage)	±5 V; 0 ... 5 V; 1 ... 5 V; ±10 V; 0 ... 10 V; 2 ... 10 V
Output signal (current)	±10 mA; 0 ... 10 mA; 2 ... 10 mA; ±20 mA; 0 ... 20 mA; 4 ... 20 mA
Load impedance (voltage output)	≥ 1 kΩ
Load impedance (current output)	≤ 600 Ω

Output – Digital

Max. switching voltage (DO)	Supply voltage applied: -0.3 V
Max. continuous current (DO)	100 mA (no internal restriction)
Number of switching thresholds (DO)	1 or 2 (adjustable)
Configurable rise/fall delay time (DO)	0 ... 60 s (via software)

Output – Relay

Number of changeover/switchover contacts	1
Contact material (relay)	AgNi + Au
Switching voltage (max.)	250 VAC
Limiting continuous current (relay; module assembly)	6 A (≤ 60 °C); 3 A (60 ... +70 °C)
Dielectric strength, open contact (AC, 1 min)	1 kV _{rms}
Pull-in time (typ.)	8 ms
Drop-out time (typ.)	4 ms
Bounce time (typ.)	8 ms
Number of switching thresholds (relay)	1 or 2 (adjustable)
Configurable rise/fall delay time (relay)	0 ... 60 s (via software)

Signal Processing

Measurement method	True RMS measurement; Arithmetic mean value
Limit frequency	3.3 kHz
Software filter (adjustable)	Moving average value (filter level: 30)
Step response (typ.)	60 ms (DC; for software filter 3/default setting); 250 ms (AC)

Measurement Error

Transmission error (max.)	≤ 1 % (of the full scale value)
Temperature coefficient	≤ 0.01 %/K

Power Supply

Power supply type	24 VDC
Nominal supply voltage U _s	24 VDC
Supply voltage range	±30 %
Power consumption at nominal supply voltage	≤ 50 mA (+ IDO)

Safety and Protection

Rated voltage of the measurement circuit connections per EN 61010-2-030	AC 300 V
Measurement category per EN/UL 61010-2-030	CAT II (input)
Protection type	IP20

Test voltage

Test voltage (input/output/supply)	AC 3 kV; 50 Hz; 1 min
Test voltage (measurement circuit/relay output/supply/ analog output)	3 kVAC; 50 ... 60 Hz; 1 min
Test voltage (measurement circuit/relay output/supply/ service interface)	3 kVAC; 50 ... 60 Hz; 1 min
Test voltage (analog output/service interface)	2 kVAC; 50 ... 60 Hz; 1 min

» Dip Switch configuration, see www.wago.com	
» Configuration software	Page 332
» Configuration app	Page 333
» Configuration display	Page 334
» Accessories	Page 344

Specialty Functions:



Configuration via:

**Insulation parameters per EN/UL 61010-1**

Line-to-neutral conductor voltage (AC) max.	300 V
Overvoltage category	II
Pollution degree	2
Insulation type (measurement circuit/relay output, supply, analog output and service interface)	Double insulation
Insulation type (analog output/service interface)	Basic insulation

Connection Data

Connection technology	Push-in CAGE CLAMP®
WAGO Connector	picoMAX® 5.0
Solid conductor	0.2 ... 2.5 mm ² / 24 ... 12 AWG
Fine-stranded conductor	0.2 ... 2.5 mm ² / 24 ... 12 AWG
Strip length	9 ... 10 mm / 0.35 ... 0.39 inch
Feedthrough for measurement conductor	9.5 mm Ø

Geometric Data

Width	22.5 mm / 0.886 inch
Height from upper-edge of DIN-rail	107 mm / 4.213 inch
Depth	105 mm / 4.134 inch

Mechanical Data

Mounting type	DIN-35 rail
---------------	-------------

Material Data

Weight	102.94 g
--------	----------

Environmental Requirements

Surrounding air temperature (operation)	-40 ... +70 °C
Surrounding air temperature (storage)	-40 ... +85 °C
Temperature range of the connecting cable according to EN 61010-2-201	≥ (T _{surrounding air} + 10 K)
Temperature range of connecting cable per UL 61010-2-201 (min.)	90 °C

Standards and Specifications

Conformity marking	CE
EMC immunity to interference	EN 61000-6-2; EN 61326-2-3; EN 50121-3-2
EMC emission of interference	EN 61000-6-4; EN 61326-2-3; EN 50121-3-2
Standards/specifications	EN 61010-1; EN 61373

Current Signal Conditioner; Configurable; with Digital Output 857 Series

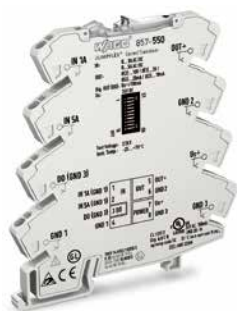

3

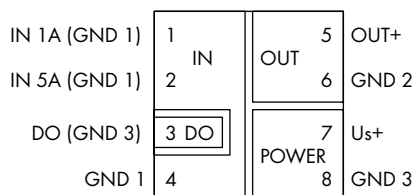

Current Signal Conditioner; Current input signal:
5 A AC/DC; Current and voltage output signal; Digital
output; Supply voltage: 24 VDC; Module width: 6 mm

Item No.	Pack. Unit
857-550	1

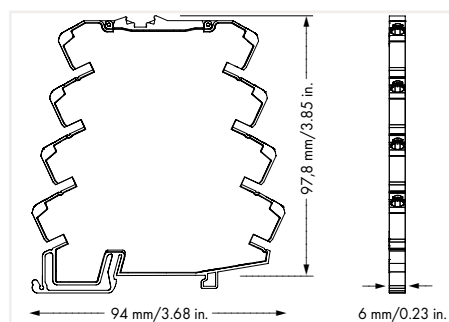

Short description:

WAGO's current signal conditioner measures both 0–1 A and 0–5 A AC/DC currents, converting the input signal to an standard analog signal at the output.

Features:

- PC configuration interface
- True RMS measurement or arithmetic mean value
- Digital switching output (configurable switching thresholds)
- Switchable filter function
- Calibrated measurement range switching
- Safe 3-way isolation with 2.5 kV test voltage per EN 61140
- Extremely fast response times
- Measurement range overflow indication

Note:

Additional setting options via interface configuration software/app

Configuration	
Configuration options	DIP switch; Interface configuration software; Interface configuration app

Input	
Input signal type	Current
Input signal (current)	0 ... 1 A AC/DC (IN 1); 0 ... 5 A AC/DC (IN 2)
Frequency range	16 ... 400 Hz
Input resistance (current input)	47 mΩ (IN 1); 10 mΩ (IN 2)
Input current (max.)	10 A (IN 1; 5 s); 15 A (IN 2; 5 s)
Response threshold	2 mA (IN 1); 4 mA (IN 2)

Output	
Output signal type	Current; Voltage
Output signal (voltage)	0 ... 5 V; 1 ... 5 V; 0 ... 10 V; 2 ... 10 V
Output signal (current)	0 ... 10 mA; 2 ... 10 mA; 0 ... 20 mA; 4 ... 20 mA
Load impedance (voltage output)	≥ 2 kΩ (temperature range restrictions may occur)
Load impedance (current output)	≤ 600 Ω (temperature range restrictions may occur)

Output – Digital	
Max. switching voltage (DO)	Supply voltage applied
Max. continuous current (DO)	100 mA (no internal restriction)
Number of switching thresholds (DO)	1 (adjustable)

Signal Processing	
Measurement method	True RMS measurement; Arithmetic mean value
Software filter (adjustable)	Moving average value (filter level: 30)
Step response (typ.)	60 ms

Measurement Error	
Transmission error (typ.)	≤ 0.1 % of upper-range value
Transmission error (max.)	≤ 0.4 % of upper-range value
Temperature coefficient	≤ 0.01 %/K

Power Supply	
Power supply type	24 VDC
Nominal supply voltage U_s	24 VDC
Supply voltage range	±30 %
Power consumption at nominal supply voltage	≤ 40 mA (+ IDO)

Safety and Protection	
Test voltage (input/output/supply)	2.5 kVAC; 50 Hz; 1 min
Protection type	IP20

Connection Data	
Connection technology	Push-in CAGE CLAMP®
Solid conductor	0.08 ... 2.5 mm ² / 28 ... 14 AWG
Fine-stranded conductor	0.34 ... 2.5 mm ² / 22 ... 14 AWG
Strip length	9 ... 10 mm / 0.35 ... 0.39 inch

Geometric Data	
Width	6 mm / 0.236 inch
Height from upper-edge of DIN-rail	97.8 mm / 3.85 inch
Depth	94 mm / 3.701 inch

Mechanical Data	
Mounting type	DIN-35 rail

Material Data	
Weight	64 g

Environmental Requirements	
Surrounding air temperature (operation)	–25 °C ... +70 °C (at nominal current)
Surrounding air temperature (storage)	–40 ... +85 °C
Relative humidity	5 ... 95 % (no condensation permissible)
Operating altitude (max.)	2000 m

Standards and Specifications	
Conformity marking	CE
EMC immunity to interference	EN 61000-6-2
EMC emission of interference	EN 61000-6-4

» Configuration software	Page 332
» Configuration app	Page 333
» Accessories	Page 344

Specialty Functions:



Configuration via:



857-550

DIP Switch Adjustability

= ON Default

DIP Switch S1

Input Signal		Measurement Method	Filter	Output Signal		
1	2	3	4	5	6	
5 A	Mean square value	off				0 ... 20 mA
• 1 A	• Arithmetic mean value	• active		•		4 ... 20 mA
				•		0 ... 10 V
				•	•	2 ... 10 V
					•	0 ... 10 mA
					•	2 ... 10 mA
				•		0 ... 5 V
				•	•	1 ... 5 V

Filter:

The filter function allows a low-pass filter to be switched on in order to mask or "smooth out" oscillating measured values (e.g., during trailing edge flows).

DIP Switch S1

7	8	Measurement Range Underflow	Measurement Range Overflow	Overcurrent (Input Signal - End Value + 20%)	9	10	Digit Output DO Signaling
		Lower limit of measurement range -5 %*	Upper limit of measurement range +2.5 %*	Upper limit of measurement range +5 %*			DO not active
•		Lower limit of measurement range	Upper limit of measurement range +2.5 %	Upper limit of measurement range +5 %		•	DO U _s + switching
	•	Lower limit of measurement range	Upper limit of measurement range	Lower limit of measurement range	•	•	DO GND switching
	•	Lower limit of measurement range	Upper limit of measurement range	Upper limit of measurement range			*acc. to NAMUR NE 43

Current Signal Conditioner; Configurable; with Digital Output Serie 857

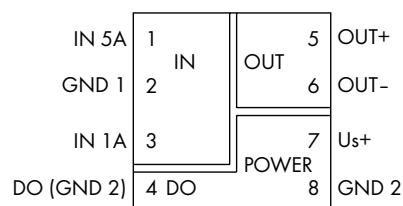

Current Signal Conditioner; Current input signal: 5 A AC/DC; Current and voltage output signal; Digital output; Supply voltage: 24 VDC; Module width: 6 mm

Item No.	Pack. Unit
857-551	1

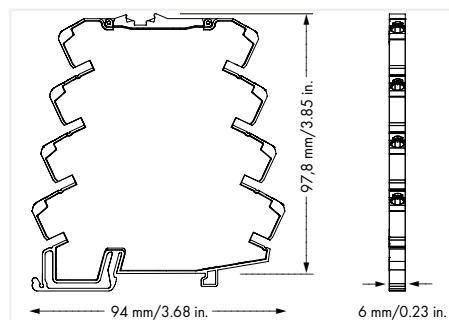

Short description:

WAGO's current signal conditioner measures AC/DC currents up to 5 A, converting the input signal to a standard analog signal at the output.

Features:

- Two isolated measurement inputs for 1 and 5 A AC/DC
- RMS measurement or arithmetic mean value
- A digital signal output reacts to configured measurement range limits (on/off switching delay and threshold value switch function can be configured with up to two threshold values)
- Switchable filter function
- Safe 3-way isolation with 3 kV test voltage per DIN EN 61010-1

Notes:

- Additional setting options via interface configuration software
- In the present network, ensure that the neutral conductor is not dangerously active!

Configuration	
Configuration options	DIP switch; Interface configuration software

Input	
Input signal type	Current
Input signal (current)	0 ... 5 A AC/DC (IN 1; Individual arrangement); 0 ... 6 A AC/DC (IN 1; Block arrangement)
Frequency range	16 ... 200 Hz
Input resistance (current input)	47 mΩ (IN 1); 10 mΩ (IN 2)
Input current (max.)	15 A (IN 1; 5 s); 10 A (IN 3; 5 s)
Response threshold	10 mA (IN 1); 2 mA (IN 2)
Resolution	1 mA (IN 1); 0.5 mA (IN 2)

Output	
Output signal type	Current; Voltage
Output signal (voltage)	0 ... 5 V; 1 ... 5 V; 0 ... 10 V; 2 ... 10 V (can be inverted, also bipolar)
Output signal (current)	0 ... 10 mA; 2 ... 10 mA; 0 ... 20 mA; 4 ... 20 mA (can be inverted, also bipolar)
Load impedance (voltage output)	≥ 2 kΩ
Load impedance (current output)	≤ 600 Ω

Output – Digital	
Max. switching voltage (DO)	Supply voltage applied
Max. continuous current (DO)	100 mA (no internal restriction)
Number of switching thresholds (DO)	1 or 2 (adjustable)
Configurable rise/fall delay time (DO)	0 ... 60 s (via software)

Signal Processing	
Measurement method	True RMS measurement; Arithmetic mean value
Software filter (adjustable)	Moving average value (filter level: 30)
Step response (typ.)	60 ms (with software filter 3)
Step response (max.)	250 ms

Measurement Error	
Transmission error (max.)	≤ 0.5 % (of the full scale value)
Temperature coefficient	1-A-input: ≤ 0,01 %/K (typ.); ≤ 0,02 %/K (max.); 5-A-input: ≤ 0,02 %/K (typ.); ≤ 0,04 %/K (max.)

Power Supply	
Nominal supply voltage U_s	24 VDC (SELV)
Supply voltage range	±30 %
Power consumption at nominal supply voltage	≤ 50 mA (+ IDO)

Safety and Protection	
Measurement category per EN 61010-2-030	CAT II (input 300 VAC)
Note on insulation parameters	Danger: Configuration via the service interface must only be performed with a voltage-free measurement input! The digital output (DO) is at the potential of the supply
Protection type	IP20

Test voltage	
Test voltage (input/analog output/supply/service interface)	3 kVAC; 50 Hz; 1 min

Insulation parameters per EN 61010-1	
Line-to-neutral conductor voltage (AC) max.	300 V
Line-to-neutral conductor voltage (DC) max.	300 V
Overvoltage category	II
Pollution degree	2
Insulation type (input/analog output/supply/service interface)	Double insulation (impedance and basic insulation) Requirement: The GND 1 input is dangerous when active and the measurement is conducted as a low-side measurement!

Connection Data	
Connection technology	Push-in CAGE CLAMP®
Solid conductor	0.08 ... 2.5 mm ² / 28 ... 14 AWG
Fine-stranded conductor	0.34 ... 2.5 mm ² / 22 ... 14 AWG
Strip length	9 ... 10 mm / 0.35 ... 0.39 inch

Geometric Data	
Width	6 mm / 0.236 inch
Height from upper-edge of DIN-rail	97.8 mm / 3.85 inch
Depth	94 mm / 3.701 inch

» Configuration software	Page 332
» Accessories	Page 344

Specialty Functions:



Configuration via:



Mechanical Data	
Mounting type	DIN-35 rail
Material Data	
Weight	38.2 g
Environmental Requirements	
Surrounding air temperature (operation)	-40 °C ... +70 °C (at nominal current)
Surrounding air temperature (storage)	-40 ... +85 °C
Temperature range of the connecting cable according to EN 61010-2-201	≥ (T _{surrounding air} + 34 K)
Relative humidity	5 ... 95 % (no condensation permissible)
Operating altitude (max.)	2000 m
Standards and Specifications	
Conformity marking	CE
EMC immunity to interference	EN 61000-6-2; EN 61326-1
EMC emission of interference	EN 61000-6-3; EN 61326-1
Standards/specifications	EN 61010-1

857-551

DIP Switch Adjustability

● = ON **Default**

DIP Switch S1

1	2	Input	3	Measurement Method	4	Filter
		5 A		Effective value (RMS)		off
	●	2.5 A	●	Arithmetic mean value (bipolar output)	●	active
	●	1 A				
	● ●	0.5 A				

DIP Switch S1

5	6	7	Output Signal Range (Bipolar for Arithmetic Mean Value)
			(+/-) 0 ... 20 mA
	●		4 ... 20 mA
●			(+/-) 0 ... 10 V
● ●			2 ... 10 V
	●		(+/-) 0 ... 10 mA
● ●			2 ... 10 mA
●	●		(+/-) 0 ... 5 V
● ● ●			1 ... 5 V

DIP Switch S1

8	9	Measurement Range Underflow	Measurement Range Overflow	10	Digital Output DO Signaling
		Lower limit of measurement range +2.5 %*	Upper limit of measurement range -5 %*		DO U _s switching
●		Lower limit of measurement range +2.5 %	Upper limit of measurement range	●	DO GND switching
	●	Lower limit of measurement range	Upper limit of measurement range		
● ●		Lower limit of measuring range	Upper limit of measuring range -5 %		

*acc. to NAMUR NE 43

Filter

The filter function allows a low-pass filter to be switched on in order to mask or "smooth out" oscillating measured values (e.g., during trailing edge flows).

Digital Output DO/Signaling

The digital output (DO) signals error messages and can be configured as follows: 24 V → 0 V/0 V → 24 V.

Current Signal Conditioner; Configurable; Input for Rogowski Coils 857 Series



3

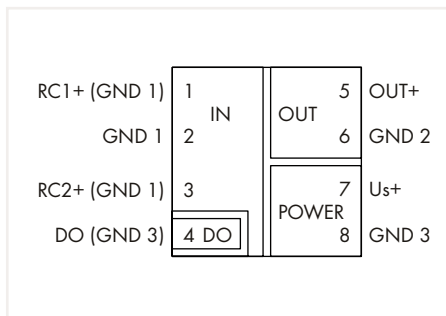

Current Signal Conditioner; Input for Rogowski coils;
Current and voltage output signal; Digital output; Sup-
ply voltage: 24 VDC; Module width: 6 mm

Item No.	Pack. Unit
857-552	1

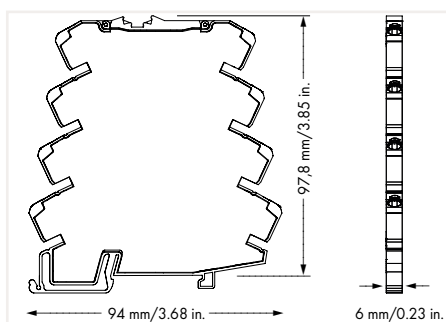

Short description:

WAGO's rogowski signal conditioner records RMS values from alternating currents via Rogowski coil, converting the input signal into a standard analog signal on the output side.

Features:

- PC configuration interface
- Supports different Rogowski coil types
- Digital switching output (configurable switching thresholds)
- True RMS measurement (TRMS)
- Configurable output signal
- Configuration via DIP switch
- Safe 3-way isolation with 2.5 kV test voltage per EN 61140
- No current bar interruption during installation
- Measurement range overflow indication

Note:

Additional setting options via interface configuration software/app

Configuration	
Configuration options	DIP switch; Interface configuration software; Interface configuration app
Input	
Input signal type	Voltage
Input signal (voltage)	50 Hz sinusoidal signals: 10.05 mVAC (RC1); 40.2 mVAC (RC2A); 90 mVAC (RC2B)
Sensitivity	RC2B: 22.5 mV/kA
Measurement range (current)	500 AAC (RC1); 2000 AAC (RC2A); 4000 AAC (RC2B)
Frequency range	50 Hz (sinusoidal signals)
Response threshold	≤ 1 % (of measurement range nominal value)
Resolution	250 mA (RC1); 1 A (RC2A); 1.5 A (RC2B)
Output	
Output signal type	Current; Voltage
Output signal (voltage)	0 ... 5 V; 1 ... 5 V; 0 ... 10 V; 2 ... 10 V
Output signal (current)	0 ... 10 mA; 2 ... 10 mA; 0 ... 20 mA; 4 ... 20 mA
Load impedance (voltage output)	≥ 1 kΩ
Load impedance (current output)	≤ 600 Ω
Output – Digital	
Max. switching voltage (DO)	Supply voltage applied
Max. continuous current (DO)	100 mA (no internal restriction)
Number of switching thresholds (DO)	1 (adjustable)
Signal Processing	
Measurement method	True RMS measurement (TRMS)
Limit frequency	2 kHz
Software filter (adjustable)	Moving average value (filter level: 30)
Step response (typ.)	60 ms
Measurement Error	
Transmission error (max.)	≤ 1 % (of the full scale value)
Temperature coefficient	≤ 0.01 %/K
Power Supply	
Power supply type	24 VDC
Nominal supply voltage U_s	24 VDC
Supply voltage range	±30 %
Power consumption at nominal supply voltage	≤ 40 mA (+ IDO)
Safety and Protection	
Test voltage (input/output/supply)	2.5 kVAC; 50 Hz; 1 min
Protection type	IP20
Connection Data	
Connection technology	Push-in CAGE CLAMP®
Solid conductor	0.08 ... 2.5 mm ² / 28 ... 14 AWG
Fine-stranded conductor	0.34 ... 2.5 mm ² / 22 ... 14 AWG
Strip length	9 ... 10 mm / 0.35 ... 0.39 inch
Geometric Data	
Width	6 mm / 0.236 inch
Height from upper-edge of DIN-rail	97.8 mm / 3.85 inch
Depth	94 mm / 3.701 inch
Mechanical Data	
Mounting type	DIN-35 rail
Material Data	
Weight	35.1 g
Environmental Requirements	
Surrounding air temperature (operation)	-25 ... +70 °C
Surrounding air temperature (storage)	-40 ... +85 °C
Relative humidity	5 ... 95 % (no condensation permissible)
Operating altitude (max.)	2000 m
Standards and Specifications	
Conformity marking	CE

» Configuration software	Page 332
» Configuration app	Page 333
» Accessories	Page 344

Specialty Functions:



Configuration via:



857-552

DIP Switch Adjustability

● = ON Default

DIP Switch S1

Input Signal		RC Configuration Input		Filter	Output Signal		
1	2	3	4	5	6		
RC1 = RT500 from LEM	RC2A = RT2000 from LEM	off				0 ... 20 mA	
● RC2	● RC2B = 22.5 mV/kA	● active		●		4 ... 20 mA	
				●		0 ... 10 V	
				●	●	2 ... 10 V	
					●	0 ... 10 mA	
					●	2 ... 10 mA	
				●	●	0 ... 5 V	
				●	●	1 ... 5 V	

Filter:

The filter function allows a low-pass filter to be switched on in order to mask or "smooth out" oscillating measured values (e.g., during trailing edge flows).

DIP Switch S1

7	8	Measurement Range Underflow	Measurement Range Overflow	Overcurrent (Input Signal – End Value + 20%)	9	10	Digital Output DO Signaling
		Lower limit of measurement range +5 %*	Upper limit of measurement range +2.5 %*	Upper limit of measurement range +5 %*			DO not active
●		Lower limit of measurement range	Upper limit of measurement range +2.5 %	Upper limit of measurement range +5 %		●	DO U _s + switching
	●	Lower limit of measurement range	Upper limit of measurement range	Lower limit of measurement range	●	●	DO GND switching
●	●	Lower limit of measurement range	Upper limit of measurement range	Upper limit of measurement range			*acc. to NAMUR NE 43

Voltage Signal Conditioner; Configurable; with Digital Output 857 Series



3

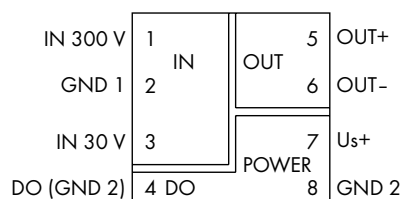

Voltage Signal Conditioner; Voltage input signal; Current and voltage output signal; Digital output; Supply voltage: 24 VDC; Module width: 6 mm

Item No.	Pack. Unit
857-560	1

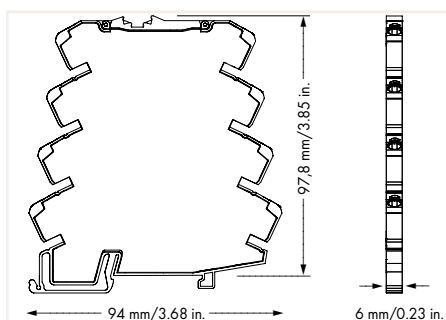

Short description:

WAGO's voltage signal conditioner measures AC/DC voltages up to 300 V, converting the input signal into a standard analog signal at the output.

Features:

- Two isolated measurement inputs for 30 and 300 V AC/DC
- RMS measurement or arithmetic mean value
- A digital signal output reacts to configured measurement range limits (on/off switching delay and threshold value switch function can be configured with up to two threshold values)
- Switchable filter function
- Safe 3-way isolation with 3 kV test voltage per DIN EN 61010-1

Configuration	
Configuration options	DIP switch; Interface configuration software; Interface configuration app

Input	
Input signal type	Voltage
Input signal (voltage)	300 V AC/DC (IN 1); 30 V AC/DC (IN 2)
Frequency range	10 ... 100 Hz (AC)
Input resistance (voltage input)	≥ 300 kΩ
Response threshold	300 mV (IN 1); 30 mV (IN 2)
Resolution	30 mV (IN 1); 3 mV (IN 2)

Output	
Output signal type	Current; Voltage
Output signal (voltage)	0 ... 5 V; 1 ... 5 V; 0 ... 10 V; 2 ... 10 V (can be inverted, also bipolar)
Output signal (current)	0 ... 10 mA; 2 ... 10 mA; 0 ... 20 mA; 4 ... 20 mA (can be inverted, also bipolar)
Load impedance (voltage output)	≥ 1 kΩ
Load impedance (current output)	≤ 600 Ω

Output – Digital	
Max. switching voltage (DO)	Supply voltage applied
Max. continuous current (DO)	100 mA (no internal restriction)
Number of switching thresholds (DO)	1 or 2 (adjustable)
Configurable rise/fall delay time (DO)	0 ... 60 s (via software)

Signal Processing	
Measurement method	RMS measurement; Arithmetic mean value
Limit frequency	2 kHz
Software filter (adjustable)	Moving average value (filter level: 30)
Step response (typ.)	30 ms

Measurement Error	
Transmission error (max.)	≤ 0.5 % (of the full scale value)
Temperature coefficient	≤ 0.01 %/K

Power Supply	
Power supply type	24 VDC
Nominal supply voltage U_s	24 VDC
Supply voltage range	±30 %
Power consumption at nominal supply voltage	≤ 46 mA (+ IDO)

Safety and Protection	
Measurement category per EN/UL 61010-2-030	CAT II (input)
Note on insulation parameters	Danger: Configuration via the service interface must only be performed with a voltage-free measurement input! The digital output (DO) is at the potential of the supply
Protection type	IP20

Test voltage	
Test voltage (input/analog output/supply/service interface)	2.5 kVAC; 50 ... 60 Hz; 1 min

Insulation parameters per EN/UL 61010-1	
Line-to-neutral conductor voltage (AC) max.	150 V
Overvoltage category	II
Pollution degree	2
Insulation type (input/analog output/supply/service interface)	Reinforced insulation

Insulation parameters per EN 61010-1	
Line-to-neutral conductor voltage (AC) max.	300 V
Overvoltage category	II
Pollution degree	2
Insulation type (input/analog output/supply/service interface)	Double insulation (impedance and basic insulation) Requirement: The GND 1 input is dangerous when active and the measurement is conducted as a low-side measurement!

Connection Data	
Connection technology	Push-in CAGE CLAMP®
Solid conductor	0.08 ... 2.5 mm ² / 28 ... 14 AWG
Fine-stranded conductor	0.34 ... 2.5 mm ² / 22 ... 14 AWG
Strip length	9 ... 10 mm / 0.35 ... 0.39 inch

» Configuration software	Page 332
» Configuration app	Page 333
» Accessories	Page 344

Specialty Functions:



Configuration via:



Geometric Data

Width	6 mm / 0.236 inch
Height from upper-edge of DIN-rail	97.8 mm / 3.85 inch
Depth	94 mm / 3.701 inch

Mechanical Data

Mounting type	DIN-35 rail
---------------	-------------

Material Data

Weight	40 g
--------	------

Environmental Requirements

Surrounding air temperature (operation)	-25 °C ... +70 °C (at nominal current)
Surrounding air temperature (storage)	-40 ... +85 °C
Temperature range of the connecting cable according to EN 61010-2-201	≥ (Tsurrounding air + 10 K)
Temperature range of connecting cable per UL 61010-2-201 (min.)	90 °C
Relative humidity	5 ... 95 % (no condensation permissible)
Operating altitude (max.)	2000 m

Standards and Specifications

Conformity marking	CE
EMC immunity to interference	EN 61000-6-2; EN 61326-2-3; EN 50121-3-2
EMC emission of interference	EN 61000-6-3; EN 61326-2-3; EN 50121-3-2
Standards/specifications	EN 61010-1; EN 61373

857-560

DIP Switch Adjustability

● = ON Default

DIP Switch S1

1	2	Input	3	Measurement Method	4	Filter
		300 V		Effective value (RMS)		off
●		150 V	●	Arithmetic mean value (bipolar output)	●	active
●		30 V				
●	●	15 V				

DIP Switch S1

5	6	7	Output Signal Range (Bipolar for Arithmetic Mean Value)
			(+/-) 0 ... 20 mA
●			4 ... 20 mA
●			(+/-) 0 ... 10 V
●	●		2 ... 10 V
	●		(+/-) 0 ... 10 mA
●	●		2 ... 10 mA
●	●		(+/-) 0 ... 5 V
●	●	●	1 ... 5 V

DIP Switch S1

8	9	Measurement Range Underflow	Measurement Range Overflow	10	Digital Output DO/ Signaling
		Lower limit of measurement range -5 %*	Upper limit of measurement range +2.5 %*		DO V _s + switching
●		Lower limit of measurement range	Upper limit of measurement range +2.5 %	●	DO GND switching
	●	Lower limit of measurement range	Upper limit of measurement range		
●	●	Lower limit of measurement range	Upper limit of measurement range		

*acc. to NAMUR NE 43

Filter

The filter function allows a low-pass filter to be switched on in order to mask or "smooth out" oscillating measured values (e.g., during trailing edge flows).

Digital Output DO/Signaling

The digital output (DO) signals error messages and can be configured as follows: 24 V → 0 V/0 V → 24 V.

Voltage Signal Conditioner; Configurable 857 Series



IN+	1	IN mV	OUT	5	OUT+
IN-	2		U _I	6	GND 1
N.C.	3	POWER	7	U _S +	
N.C.	4		8	GND 2	

Voltage Signal Conditioner; Bipolar voltage input signal;
Current and voltage output signal; Supply voltage:
24 VDC; Module width: 6 mm

Item No.	Pack. Unit
857-819	1

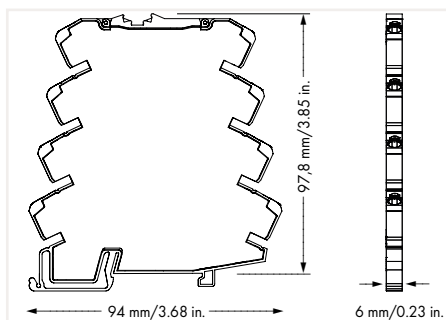

Short description:

WAGO's voltage signal conditioner converts millivolt signals (at the input) into a standard analog signal at the output.

Features:

- PC configuration interface
- Calibrated measurement range switching
- Switchable clipping
- Limitation of standard analog signal to upper range values
- Safe 3-way isolation with 2.5 kV test voltage per EN 61140

Note:

Additional setting options via interface configuration software/app

Configuration

Configuration options	DIP switch; Interface configuration software; Interface configuration app
-----------------------	--

Input

Input signal type	Voltage
Input signal (voltage)	±100 mV; 0 ... 200 mV; 0 ... 300 mV; 0 ... 400 mV; 0 ... 500 mV; 0 ... 600 mV; 0 ... 700 mV; 0 ... 800 mV; 0 ... 900 mV; 0 ... 1 V
Input resistance (voltage input)	≥ 1 MΩ
Input voltage (max.)	±31.2 VDC
Measurement span (voltage)	10 mV

Output

Output signal type	Current; Voltage
Output signal (voltage)	0 ... 5 V; 1 ... 5 V; 0 ... 10 V; 2 ... 10 V
Output signal (current)	0 ... 10 mA; 2 ... 10 mA; 0 ... 20 mA; 4 ... 20 mA
Load impedance (voltage output)	≥ 2 kΩ
Load impedance (current output)	≤ 600 Ω

Signal Processing

Step response (typ.)	50 ms
----------------------	-------

Measurement Error

Transmission error (typ.)	≤ 0.1 % at full measurement span
Temperature coefficient	≤ 0.01 %/K

Power Supply

Power supply type	24 VDC
Nominal supply voltage U _s	24 VDC
Supply voltage range	±30 %
Power consumption at nominal supply voltage	≤ 40 mA

Safety and Protection

Test voltage (input/output/supply)	2.5 kVAC; 50 Hz; 1 min
Protection type	IP20

Connection Data

Connection technology	Push-in CAGE CLAMP®
Solid conductor	0.08 ... 2.5 mm ² / 28 ... 14 AWG
Fine-stranded conductor	0.34 ... 2.5 mm ² / 22 ... 14 AWG
Strip length	9 ... 10 mm / 0.35 ... 0.39 inch

Geometric Data

Width	6 mm / 0.236 inch
Height from upper-edge of DIN-rail	97.8 mm / 3.85 inch
Depth	94 mm / 3.701 inch

Mechanical Data

Mounting type	DIN-35 rail
---------------	-------------

Material Data

Weight	36.3 g
--------	--------

Environmental Requirements

Surrounding air temperature (operation)	-25 ... +70 °C
Surrounding air temperature (storage)	-40 ... +85 °C
Relative humidity	5 ... 95 % (no condensation permissible)
Operating altitude (max.)	2000 m

Standards and Specifications

Conformity marking	CE
EMC immunity to interference	EN 61000-6-2
EMC emission of interference	EN 61000-6-4

» Configuration software	Page 332
» Configuration app	Page 333
» Accessories	Page 344

1-Phase Power Signal Conditioner; with Digital Output; Configuration via Software

2857 Series



1.1	N.C.	Relay Output	Analog Output (AO)	OUT+	4.1
1.2	12			OUT-	4.2
1.3	11			OUT+	4.3
1.4	14			OUT-	4.4
2.1	500 V	Voltage IN	Supply Voltage	U _s +	5.1
2.2	250 V			GND 2	5.2
2.3	30 V			DO (GND 2)	5.3
3.1	N (GND 1)	Current IN	Digital Output (DO)	GND 2	5.4
3.2	1 A			U _s +	6.1
3.3	5 A			GND 2	6.2
3.4	8 A				

1-Phase Power Measurement Module; Current and voltage input signal; Current and voltage output signal; Digital output; Configuration via software; Supply voltage: 24 VDC

Item No.	Pack. Unit
2857-569	1

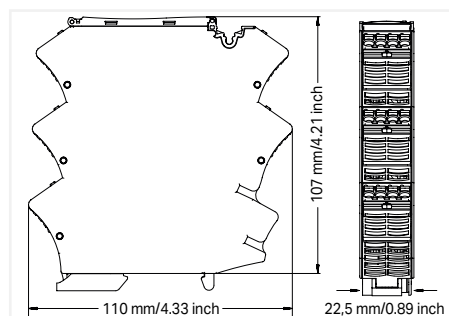

Short description:

Short description:

The WAGO 1-Phase Power Measurement Module monitors and reports signal states with up to two switching thresholds. The sensor and status information that is collected is also converted to a standard analog signal. Current, voltage, effective power, apparent power or reactive power can be selected as the measured variable. Additionally, both frequency and phase angle are displayed.

Additionally, both frequency and phase angle are displayed.

Features:

- A relay with changeover contact reacts to configured measurement range limits (on/off switching delay and threshold value switch function can be configured with up to two threshold values).
- Adjustable software filter
- Input/output response simulation via WAGO Configuration Display
- Analog unipolar/bipolar signals (current/voltage) at output
- Additional digital signal output for configured measurement range limits
- The digital output can be configured as a frequency generator or pulse output (S0 interface).

Note:

Additional setting options via WAGO Interface Configuration Software or WAGO Configuration Display

» Configuration software	Page 332
» Configuration display	Page 333
» Accessories	Page 344

Configuration

Configuration options WAGO Interface Configuration Software; WAGO Configuration Display

Input

Input signal type	Voltage; Current
Input signal (voltage)	500 V AC/DC (IN 2.1; per EN 61010-1); 300 V AC/DC (IN 2.1; per UL 61010-1); 250 V AC/DC (IN 2.2); 30 V AC/DC (IN 2.3)
Input signal (current)	1 A AC/DC (IN 3.1); 5 A AC/DC (IN 3.2); 8 A AC/DC (IN 3.3)
Frequency range	15 ... 400 Hz (AC)
Input voltage (max.)	$1.2 \times U_N$
Input current (max.)	$1.2 \times I_N (\leq 60^\circ\text{C}); 1 \times I_N (60 \dots 70^\circ\text{C})$
Response threshold (voltage)	500 mV AC / 600 mV DC (IN 2.1); 50 mV AC / 500 mV DC (IN 2.2); 20 mV AC / 100 mV DC (IN 2.3)
Response threshold (current)	1.5 mA AC / 7.5 mA DC (IN 3.1); 3 mA AC / 10 mA DC (IN 3.2); 7.5 mA AC / 12 mA DC (IN 3.3)
Resolution (voltage)	50 mV (IN 2.1); 30 mV (IN 2.2); 5 mV (IN 2.3)
Resolution (current)	1 mA (for all measurement ranges)

Output – Analog

Output signal type	Current; Voltage
Output signal (voltage)	± 12 V (SELV)
Output signal (current)	± 24 mA (SELV)
Load impedance (voltage output)	≥ 2 k Ω
Load impedance (current output)	≤ 600 Ω

Output – Digital

Switching voltage (DO) (max.)	Supply voltage (applied): -0.3 V
Continuous current (DO) (max.)	100 mA (no internal restriction)
Number of switching thresholds (DO)	2 (max.)
Configurable rise/fall delay time (DO)	0 ... 60 s (via software)
Configurable functions (DO)	Disabled; U _s /GND switching; Threshold value switch; Frequency generator; Pulse output (S0 interface)

Output – Relays

Number of changeover/switchover contacts	1
Switching voltage (max.)	250 VAC
Limiting continuous current (relay; module assembly)	6 A ($\leq 60^\circ\text{C}$); 3 A (60 ... 70 °C)
Dielectric strength, open contact (AC, 1 min)	1 kV _{rms}
Number of switching thresholds (relay)	1 or 2 (adjustable)
Configurable rise/fall delay time (relay)	0 ... 60 s (via software)

Signal Processing

Measurement method	True RMS measurement (TRMS)
Measured variables (calculated)	Active power; Apparent power; Reactive power; Phase angle; Mains frequency
Limit frequency	2 kHz
Software filter (adjustable)	Filter level: 1 ... 30
Step response (max.)	≤ 350 ms (default settings)

Measurement Error

Transmission error (max.)	≤ 0.5 % for current and voltage (of the full scale value)
---------------------------	--

Power Supply

Power supply type	24 VDC
Nominal supply voltage U _s	24 VDC (SELV)
Supply voltage range	± 30 %
Power consumption at nominal supply voltage	≤ 70 mA (+ I ₀₀)

Safety and Protection

Measurement category per EN/UL 61010-2-030	CAT III (input)
Overvoltage category	III
Note on insulation parameters	The digital output (DO) is at the potential of the supply. The service interface is at the potential of the analog output.
Protection type	IP20

Specialty Functions:



Configuration via:



Test voltage	
Test voltage (input IN 2.1/relay output; per EN 61010-1)	5.4 kVAC ; 50 Hz; 5 s; 3.6 kVAC; 50 Hz; 1 min
Test voltage (input IN 2.1/relay output; per UL 61010-1)	3.51 kVAC; 60 Hz; 1 min
Test voltage (input/supply, analog output/relay output)	3.51 kVAC; 50 ... 60 Hz; 1 min
Test voltage (supply/analog output)	3.6 kVAC; 50 ... 60 Hz; 1 min
Insulation parameters per EN/UL 61010-1	
Line-to-neutral conductor voltage (AC) max.	300 V
Overvoltage category	III
Pollution degree	2
Insulation type (input/supply, analog output/relay output)	Reinforced insulation
Insulation parameters per EN 61010-1	
Line-to-neutral conductor voltage (AC) max.	600 V
Overvoltage category	III
Pollution degree	2
Insulation type (input IN 2.1/relay output)	Reinforced insulation
Insulation type (input/supply, analog output/relay output)	Double insulation (impedance and basic insulation) Requirement: The N (GND 1) input is dangerous when active!
Connection Data	
Connection technology	Push-in CAGE CLAMP®
WAGO Connector	picoMAX® 5.0
Solid conductor	0.2 ... 2.5 mm ² / 24 ... 12 AWG
Fine-stranded conductor	0.2 ... 2.5 mm ² / 24 ... 12 AWG
Strip length	9 ... 10 mm / 0.35 ... 0.39 inch
Physical Data	
Width	22.5 mm / 0.886 inch
Height from upper-edge of DIN-rail	107 mm / 4.213 inch
Depth	110 mm / 4.331 inch
Mechanical Data	
Mounting type	DIN-35 rail
Material Data	
Weight	149 g
Environmental Requirements	
Surrounding air temperature (operation)	-40 ... +70 °C
Surrounding air temperature (storage)	-40 ... +85 °C
Temperature range of connecting cable per EN 61010-2-201	≥ (T _{surrounding air} + 10 K)
Temperature range of connecting cable per UL 61010-2-201	≥ 90 °C
Relative humidity	5 ... 85 % (non-condensing)
Operating altitude (max.)	2000 m
Standards and Specifications	
Conformity marking	CE
EMC immunity to interference	EN 61000-6-2; EN 61326-2-3
EMC emission of interference	EN 61000-6-3; EN 61326-2-3
Standards/Specifications	EN 61010-1; UL 61010-1; UL 61010-2-201

Power Signal Conditioner; Configurable; with Digital Output 857 Series

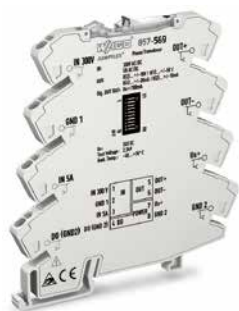

3

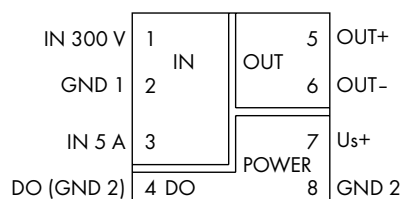

Power Signal Conditioner; 300 VAC / 5 A; Current and voltage output signal; Digital output; Supply voltage: 24 VDC; Module width: 6 mm

Item No.	Pack. Unit
857-569	1

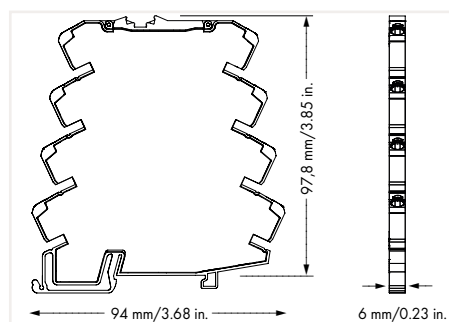

Short description:

WAGO's power signal conditioner measures both AC/DC voltages and currents, converting the input signal into a standard analog signal at the output. Measured value processing can be switched between RMS value or arithmetic mean value and between effective, apparent or reactive power, and phase angle.

Features:

- Two isolated measurement inputs for both AC/DC voltages and currents
- RMS measurement or arithmetic mean value
- A digital signal output reacts to configured measurement range limits (on/off switching delay and threshold value switch function can be configured with up to two threshold values)
- Switchable filter function
- Safe 3-way isolation with 3 kV test voltage per DIN EN 61010-1

» Configuration software	Page 332
» Configuration app	Page 333
» Accessories	Page 344

Configuration

Configuration options	DIP switch; Interface configuration software; Interface configuration app
-----------------------	---

Input

Input signal type	Voltage; Current
Input signal (voltage)	300 V AC/DC (IN 1)
Input signal (current)	0 ... 5 A AC/DC (IN 2)
Frequency range	15 ... 70 Hz (AC)
Input resistance (current input)	≤ 10 mΩ
Input resistance (voltage input)	≥ 300 kΩ
Input current (max.)	10 A AC/DC (IN 2; permanent)
Input voltage (max.)	600 V (IN 1; permanent)
Response threshold	300 mV (IN 1); 10 mA (IN 2)
Resolution	30 mV (IN 1); 1 mA (IN 2)

Output

Output signal type	Current; Voltage
Output signal (voltage)	0 ... 5 V; 1 ... 5 V; 0 ... 10 V; 2 ... 10 V (can be inverted, also bipolar)
Output signal (current)	0 ... 10 mA; 2 ... 10 mA; 0 ... 20 mA; 4 ... 20 mA (can be inverted, also bipolar)
Load impedance (voltage output)	≥ 1 kΩ
Load impedance (current output)	≤ 600 Ω

Output – Digital

Max. switching voltage (DO)	Supply voltage applied
Max. continuous current (DO)	100 mA (no internal restriction)
Number of switching thresholds (DO)	1 or 2 (adjustable)
Configurable rise/fall delay time (DO)	0 ... 60 s (via software)

Signal Processing

Measurement method	RMS measurement; Arithmetic mean value
Limit frequency	2 kHz
Software filter (adjustable)	Moving average value (filter level: 30)
Step response (typ.)	100 ms

Measurement Error

Transmission error (max.)	≤ 0.5 % (of the full scale value)
Temperature coefficient	≤ 0.01 %/K

Power Supply

Power supply type	24 VDC
Nominal supply voltage U_s	24 VDC
Supply voltage range	±30 %
Power consumption at nominal supply voltage	≤ 46 mA (+ IDO)

Safety and Protection

Measurement category per EN/UL 61010-2-030	CAT II (input)
Note on insulation parameters	Danger: Configuration via the service interface must only be performed with a voltage-free measurement input! The digital output (DO) is at the potential of the supply
Protection type	IP20

Test voltage

Test voltage (input/analog output/supply/service interface)	2.5 kVAC; 50 ... 60 Hz; 1 min
---	-------------------------------

Insulation parameters per EN/UL 61010-1

Line-to-neutral conductor voltage (AC) max.	150 V
Overvoltage category	II
Pollution degree	2
Insulation type (input/analog output/supply/service interface)	Reinforced insulation

Insulation parameters per EN 61010-1

Line-to-neutral conductor voltage (AC) max.	300 V
Overvoltage category	II
Pollution degree	2
Insulation type (input/analog output/supply/service interface)	Double insulation (impedance and basic insulation) Requirement: The GND 1 input is dangerous when active and the measurement is conducted as a low-side measurement!

Specialty Functions:



Configuration via:



Connection Data

Connection technology	Push-in CAGE CLAMP®
Solid conductor	0.08 ... 2.5 mm ² / 28 ... 14 AWG
Fine-stranded conductor	0.34 ... 2.5 mm ² / 22 ... 14 AWG
Strip length	9 ... 10 mm / 0.35 ... 0.39 inch

Geometric Data

Width	6 mm / 0.236 inch
Height from upper-edge of DIN-rail	97.8 mm / 3.85 inch
Depth	94 mm / 3.701 inch

Mechanical Data

Mounting type	DIN-35 rail
---------------	-------------

Material Data

Weight	34 g
--------	------

Environmental Requirements

Surrounding air temperature (operation)	-25 °C ... +70 °C (at nominal current)
Surrounding air temperature (storage)	-40 ... +85 °C
Temperature range of the connecting cable according to EN 61010-2-201	≥ (T _{surrounding air} + 10 K)
Temperature range of connecting cable per UL 61010-2-201 (min.)	90 °C
Relative humidity	5 ... 95 % (no condensation permissible)
Operating altitude (max.)	2000 m

Standards and Specifications

Conformity marking	CE
EMC immunity to interference	EN 61000-6-2; EN 61326-2-3; EN 50121-3-2
EMC emission of interference	EN 61000-6-3; EN 61326-2-3; EN 50121-3-2
Standards/specifications	EN 61010-1; EN 61373

857-569

DIP Switch Adjustability

● = ON Default

DIP Switch S1

1	2	Measured Variable	3	4	Filter
		Effective power	Not assigned		Off
●		Apparent power		●	Active
●		Reactive power			
●	●	Power factor			

DIP Switch S1

5	6	7	Output Signal Range
			0 ... 20 mA
●			4 ... 20 mA
●			0 ... 10 V
●	●		2 ... 10 V
		●	0 ... 10 mA
	●		2 ... 10 mA
●	●		0 ... 5 V
●	●	●	1 ... 5 V

DIP Switch S1

8	9	Measurement Range Underflow	Measurement Range Overflow	10	Digit Output DO/Signaling
		Lower limit of measurement range -5 %*	Upper limit of measurement range +2.5 %*		DO V _s + switching
●		Lower limit of measurement range	Upper limit of measurement range +2.5 %	●	DO GND switching
	●	Lower limit of measurement range	Upper limit of measurement range		
●	●	Lower limit of measurement range	Upper limit of measurement range		

*acc. to NAMUR NE 43

Filter:

The filter function allows a low-pass filter to be switched on in order to mask or "smooth out" oscillating measured values (e.g., during trailing edge flows).

Digital Output DO/Signaling:

The digital output (DO) signals error messages and can be configured as follows: 24 V → 0 V/0 V → 24 V.

3-Phase Power Measurement Module; 3 x 400 / 690 V; 1 A; Modbus RTU Serie 2857



3

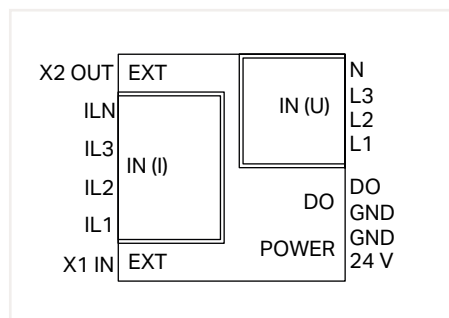

3-Phase Power Measurement Module;
3 x 400 / 690 V; 1 A; Modbus RTU

Item No.	Pack. Unit
2857-570/024-001	1

Short description:

WAGO's 3-phase power measurement module in a DIN-rail-mount enclosure measures electrical data in three-phase supply networks – remotely from the control level.

Measured variables such as active/apparent/reactive power, energy consumption, power factor, phase angle and frequency can be accessed via Modbus® Interface. In addition, the measured variables can be stored on a microSD card.

Features:

- Current measurement via 1A current transformer
- Mobile measurement and storage of measured values on microSD card
- Configuration and display of measured values during operation via configuration interface
- Compact device in DIN-rail-mount enclosure saves space used for building technology
- Communication of measured values via Modbus® Interface
- Configurable digital signal output as pulse output

Note:

- Additional setting options via interface configuration software

Specialty Functions:



Configuration via:



Configuration	
Configuration options	Interface configuration software
Input	
Input signal type	Voltage; Current
Network configuration	3-phase power measurement with N-conductor (4 conductors); 3-phase power measurement with N-conductor (3 conductors)
Input signal (voltage)	400 VAC (U_{LN}); 690 VAC (U_{LL})
Input signal (current)	1 AAC (current transformer)
Frequency range	45 ... 65 Hz (Harmonics analysis: 0 ... 3.3 kHz)
Input resistance (voltage input)	1.5 MΩ
Input resistance (current input)	22 mΩ
Input voltage (max.)	400 VAC (U_{LN}); 690 VAC (U_{LL})
Input current (max.)	1 AAC
Response threshold	10 mA
Resolution (current)	10 mA
Output – Digital	
Max. switching voltage (DO)	Supply voltage applied
Max. continuous current (DO)	100 mA (no internal restriction)
Configurable functions (DO)	Threshold value switch; S0 interface (pulse output)
Communication	
Communication	Modbus RTU
Interface	RS-485 (2-wire) via RJ-45
Number of participants (max.)	32
Addressing	Via interface configuration software
Signal Processing	
Measurement method	True RMS measurement (measured value acquisition with 8 kHz)
Measured variables (calculated)	Line-to-line voltage; Power output; Energy; Power factors; Mains frequency; Harmonic analysis (up to the 41st harmonic); Total harmonic distortion (THD)
Signal form	Any periodic signals (considering the threshold frequencies)
Limit frequency	15.9 kHz
Type of memory card	WAGO 758-879/000-3102 (microSD; 2 GB)
Measurement Error	
Transmission error (max.)	≤ 0.5 % for current and voltage (of the full scale value)
Power Supply	
Power supply type	24 VDC
Nominal supply voltage U_s	24 VDC (SELV)
Supply voltage range	±30 %
Power consumption at nominal supply voltage	≤ 50 mA (+ I_{DO})
Safety and Protection	
Test voltage (input/output/supply)	3.51 kV AC; 50 Hz; 1 min
Safe isolation (input/supply and communication)	Per EN 61010-1
Requirement (N input)	Shall not be dangerously active
Requirement (I_{Lx} input)	Coils/converters with basic insulation
External/Neutral conductor voltage	600 V AC/DC
Overtoltage category	III
Pollution degree	2
Protection type	IP20

Connection Data	
Connection type	Voltage
Connection technology	Push-in CAGE CLAMP®
WAGO Connector	WAGO 804 Series
Solid conductor	0.25 ... 2.5 mm ² / 20 ... 12 AWG
Fine-stranded conductor	0.25 ... 2.5 mm ² / 22 ... 12 AWG
Strip length	10 ... 11 mm / 0.39 ... 0.43 inch
Connection type 2	Current/Power supply/DO
Connection technology 2	Push-in CAGE CLAMP®
WAGO Connector 2	WAGO 805 Series
Solid conductor 2	0.2 ... 1.5 mm ² / 24 ... 16 AWG
Fine-stranded conductor 2	0.2 ... 1.5 mm ² / 24 ... 16 AWG
Strip length 2	9 ... 10 mm / 0.35 ... 0.39 inch
Connection type 3	Modbus® communication
Connector	2 x RJ-45 (daisy chain configuration)
Geometric Data	
Width	72 mm / 2.835 inch
Height from upper-edge of DIN-rail	55 mm / 2.165 inch
Depth	90 mm / 3.543 inch
Mechanical Data	
Mounting type	DIN-35 rail
Material Data	
Weight	115.6 g
Environmental Requirements	
Surrounding air temperature (operation)	-40 ... +70 °C
Surrounding air temperature (storage)	-40 ... +85 °C
Relative humidity	5 ... 95 % (non-condensing)
Standards and Specifications	
Conformity marking	CE
EMC immunity to interference	EN 61000-6-2
EMC emission of interference	EN 61000-6-3
Standards/specifications	EN 61010-1

3-Phase Power Measurement Module; 3 x 400 / 690 V; 5 A; Modbus RTU Serie 2857



3

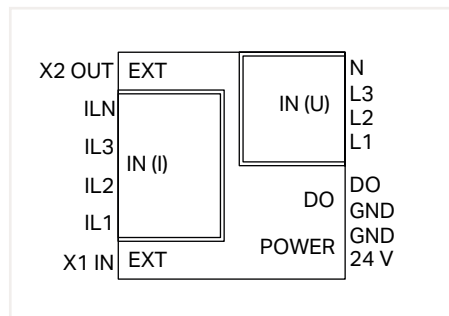

3-Phase Power Measurement Module;
3 x 400 / 690 V; 5 A; Modbus RTU

Item No.	Pack. Unit
2857-570/024-005	1

Short description:

WAGO's 3-phase power measurement module in a DIN-rail-mount enclosure measures electrical data in three-phase supply networks – remotely from the control level. Measured variables such as active/apparent/reactive power, energy consumption, power factor, phase angle and frequency can be accessed via Modbus® Interface. In addition, the measured variables can be stored on a microSD card.

Features:

- Current measurement via 5A current transformer
- Mobile measurement and storage of measured values on microSD card
- Configuration and display of measured values during operation via configuration interface
- Compact device in DIN-rail-mount enclosure saves space used for building technology
- Communication of measured values via Modbus® Interface
- Configurable digital signal output as pulse output

Note:

- Additional setting options via interface configuration software

Specialty Functions:



Configuration via:



Configuration	
Configuration options	Interface configuration software
Input	
Input signal type	Voltage; Current
Network configuration	3-phase power measurement with N-conductor (4 conductors); 3-phase power measurement with N-conductor (3 conductors)
Input signal (voltage)	400 VAC (U_{LN}); 690 VAC (U_{LL})
Input signal (current)	5 AAC (current transformer)
Frequency range	45 ... 65 Hz (Harmonics analysis: 0 ... 3.3 kHz)
Input resistance (voltage input)	1.5 MΩ
Input resistance (current input)	22 mΩ
Input voltage (max.)	400 VAC (U_{LN}); 690 VAC (U_{LL})
Input current (max.)	5 AAC
Response threshold	5 mA
Resolution (current)	0.15 mA
Output – Digital	
Max. switching voltage (DO)	Supply voltage applied
Max. continuous current (DO)	100 mA (no internal restriction)
Configurable functions (DO)	Threshold value switch; S0 interface (pulse output)
Communication	
Communication	Modbus RTU
Interface	RS-485 (2-wire) via RJ-45
Number of participants (max.)	32
Addressing	Via interface configuration software
Signal Processing	
Measurement method	True RMS measurement (measured value acquisition with 8 kHz)
Measured variables (calculated)	Line-to-line voltage; Power output; Energy; Power factors; Mains frequency; Harmonic analysis (up to the 41st harmonic); Total harmonic distortion (THD)
Signal form	Any periodic signals (considering the threshold frequencies)
Limit frequency	15.9 kHz
Type of memory card	WAGO 758-879/000-3102 (microSD; 2 GB)
Measurement Error	
Transmission error (max.)	≤ 0.5 % for current and voltage (of the full scale value)
Power Supply	
Power supply type	24 VDC
Nominal supply voltage U_s	24 VDC (SELV)
Supply voltage range	±30 %
Power consumption at nominal supply voltage	≤ 50 mA (+ I_{D0})
Safety and Protection	
Test voltage (input/output/supply)	3.51 kV AC; 50 Hz; 1 min
Safe isolation (input/supply and communication)	Per EN 61010-1
Requirement (N input)	Shall not be dangerously active
Requirement (I_{Lx} input)	Coils/converters with basic insulation
External/Neutral conductor voltage	600 V AC/DC
Overtoltage category	III
Pollution degree	2
Protection type	IP20

Connection Data	
Connection type	Voltage
Connection technology	Push-in CAGE CLAMP®
WAGO Connector	WAGO 804 Series
Solid conductor	0.25 ... 2.5 mm ² / 20 ... 12 AWG
Fine-stranded conductor	0.25 ... 2.5 mm ² / 22 ... 12 AWG
Strip length	10 ... 11 mm / 0.39 ... 0.43 inch
Connection type 2	Current/Power supply/DO
Connection technology 2	Push-in CAGE CLAMP®
WAGO Connector 2	WAGO 805 Series
Solid conductor 2	0.2 ... 1.5 mm ² / 24 ... 16 AWG
Fine-stranded conductor 2	0.2 ... 1.5 mm ² / 24 ... 16 AWG
Strip length 2	9 ... 10 mm / 0.35 ... 0.39 inch
Connection type 3	Modbus® communication
Connector	2 x RJ-45 (daisy chain configuration)
Geometric Data	
Width	72 mm / 2.835 inch
Height from upper-edge of DIN-rail	55 mm / 2.165 inch
Depth	90 mm / 3.543 inch
Mechanical Data	
Mounting type	DIN-35 rail
Material Data	
Weight	115.6 g
Environmental Requirements	
Surrounding air temperature (operation)	-40 ... +70 °C
Surrounding air temperature (storage)	-40 ... +85 °C
Relative humidity	5 ... 95 % (non-condensing)
Standards and Specifications	
Conformity marking	CE
EMC immunity to interference	EN 61000-6-2
EMC emission of interference	EN 61000-6-3
Standards/specifications	EN 61010-1

3-Phase Power Measurement Module; 3 x 400 / 690 V; RC; Modbus RTU Serie 2857

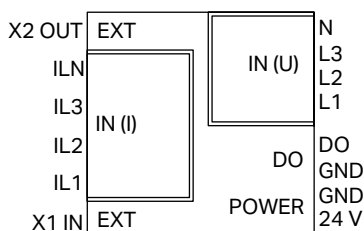

3-Phase Power Measurement Module;
3 x 400 / 690 V; RC; Modbus RTU

Item No.	Pack. Unit
2857-570/024-000	1

Short description:

WAGO's 3-phase power measurement module in a DIN-rail-mount enclosure measures electrical data in three-phase supply networks – remotely from the control level. Measured variables such as active/apparent/reactive power, energy consumption, power factor, phase angle and frequency can be accessed via Modbus® Interface. In addition, the measured variables can be stored on a microSD card.

Features:

- Current measurement via Rogowski Coils RC xxx
- Mobile measurement and storage of measured values on microSD card
- Configuration and display of measured values during operation via configuration interface
- Compact device in DIN-rail-mount enclosure saves space used for building technology
- Communication of measured values via Modbus® Interface
- Configurable digital signal output as pulse output

Note:

- Additional setting options via interface configuration software

Specialty Functions:



Configuration via:



Configuration	
Configuration options	Interface configuration software
Input	
Input signal type	Voltage; Current
Network configuration	3-phase power measurement with N-conductor (4 conductors); 3-phase power measurement with N-conductor (3 conductors)
Input signal (voltage)	400 VAC (U_{LN}); 690 VAC (U_{LL}); 90 mVAC (WAGO Rogowski Coils RC xxx)
Sensitivity	22.5 mV/kA (WAGO Rogowski Coils RC xxx)
Measurement range (current)	4000 AAC (WAGO Rogowski Coils RC xxx)
Frequency range	45 ... 65 Hz (Harmonics analysis: 0 ... 3.3 kHz)
Output – Digital	
Max. switching voltage (DO)	Supply voltage applied
Max. continuous current (DO)	100 mA (no internal restriction)
Configurable functions (DO)	Threshold value switch; S0 interface (pulse output)
Communication	
Communication	Modbus RTU
Interface	RS-485 (2-wire) via RJ-45
Number of participants (max.)	32
Addressing	Via interface configuration software
Signal Processing	
Measurement method	True RMS measurement (measured value acquisition with 8 kHz)
Measured variables (calculated)	Line-to-line voltage; Power output; Energy; Power factors; Mains frequency; Harmonic analysis (up to the 41st harmonic); Total harmonic distortion (THD)
Signal form	Any periodic signals (considering the threshold frequencies)
Limit frequency	15.9 kHz
Type of memory card	WAGO 758-879/000-3102 (microSD; 2 GB)
Measurement Error	
Transmission error (max.)	≤ 0.5 % for current and voltage (of the full scale value)
Power Supply	
Power supply type	24 VDC
Nominal supply voltage U_s	24 VDC (SELV)
Supply voltage range	±30 %
Power consumption at nominal supply voltage	≤ 50 mA (+ I_{D0})
Safety and Protection	
Test voltage (input/output/supply)	3.51 kV AC; 50 Hz; 1 min
Safe isolation (input/supply and communication)	Per EN 61010-1
Requirement (N input)	Shall not be dangerously active
Requirement (I_L input)	Coils/converters with basic insulation
External/Neutral conductor voltage	600 V AC/DC
Overtoltage category	III
Pollution degree	2
Protection type	IP20

Connection Data	
Connection type	Voltage
Connection technology	Push-in CAGE CLAMP®
WAGO Connector	WAGO 804 Series
Solid conductor	0.25 ... 2.5 mm ² / 20 ... 12 AWG
Fine-stranded conductor	0.25 ... 2.5 mm ² / 22 ... 12 AWG
Strip length	10 ... 11 mm / 0.39 ... 0.43 inch
Connection type 2	Current/Power supply/DO
Connection technology 2	Push-in CAGE CLAMP®
WAGO Connector 2	WAGO 805 Series
Solid conductor 2	0.2 ... 1.5 mm ² / 24 ... 16 AWG
Fine-stranded conductor 2	0.2 ... 1.5 mm ² / 24 ... 16 AWG
Strip length 2	9 ... 10 mm / 0.35 ... 0.39 inch
Connection type 3	Modbus® communication
Connector	2 x RJ-45 (daisy chain configuration)
Geometric Data	
Width	72 mm / 2.835 inch
Height from upper-edge of DIN-rail	55 mm / 2.165 inch
Depth	90 mm / 3.543 inch
Mechanical Data	
Mounting type	DIN-35 rail
Material Data	
Weight	117.6 g
Environmental Requirements	
Surrounding air temperature (operation)	-40 ... +70 °C
Surrounding air temperature (storage)	-40 ... +85 °C
Relative humidity	5 ... 95 % (non-condensing)
Standards and Specifications	
Conformity marking	CE
EMC immunity to interference	EN 61000-6-2
EMC emission of interference	EN 61000-6-3
Standards/specifications	EN 61010-1

RTD Threshold Value Switch; Configurable 2857 Series

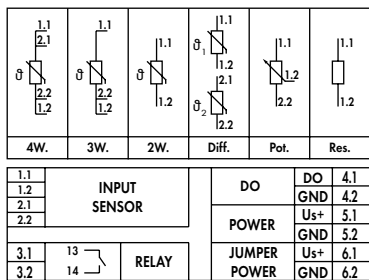

Threshold Value Switch; RTD sensors; Relay/1 make contact; Digital output; Supply voltage: 24 VDC; Module width: 12.5 mm

Item No.	Pack. Unit
2857-533	1

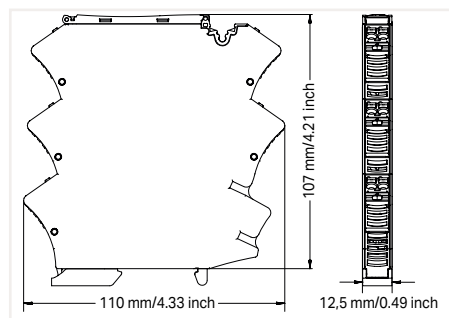

Short description:

WAGO's RTD threshold value switch for RTD sensors, potentiometers and resistors monitors and reports signals of up to two switching thresholds.

Features:

- Both digital signal output and relay with make contact react to configured measurement range limits (on/off switching delay and threshold value switch function can be configured with up to two threshold values)
- Configurable RTD factor
- Adjustable software filter
- Input/output response simulation via configuration display
- Safe 3-way isolation with 4 kV test voltage per EN 61140

Note:

Additional setting options via interface configuration software/app

Configuration	
Configuration options	DIP switch; Interface configuration software; Interface configuration app; Configuration display
Input	
Input signal type	Resistor; RTD sensors; Potentiometers
Input – RTD Sensors	
Sensor types (RTD)	Pt100; Pt200; Pt500; Pt1000; Pt5000; Pt10000; Pt10 ... Pt20000
Sensor connection	2-wire; 3-wire; 4-wire; differential
Sensor power supply (RTD) max.	≤ 0.5 mA
Temperature measurement range (RTD)	-200 ... +850 °C
Input – Resistors	
Input range (resistor)	0 ... 100 kΩ
Input range (potentiometer)	0 ... 100 kΩ
Output – Digital	
Max. switching voltage (DO)	Supply voltage applied: -0.3 V
Max. continuous current (DO)	100 mA (no internal restriction)
Number of switching thresholds (DO)	1 or 2 (adjustable)
Configurable rise/fall delay time (DO)	0 ... 60 s (via software)
Output – Relay	
Number of make contacts/switch-on contacts	1
Contact material (relay)	AgNi + Au
Switching voltage (max.)	250 VAC
Limiting continuous current (relay; module assembly)	6 A (≤ 60 °C); 3 A (60 ... +70 °C)
Dielectric strength, open contact (AC, 1 min)	1 kV _{rms}
Pull-in time (typ.)	8 ms
Drop-out time (typ.)	4 ms
Bounce time (typ.)	8 ms
Number of switching thresholds (relay)	1 or 2 (adjustable)
Configurable rise/fall delay time (relay)	0 ... 60 s (via software)
Signal Processing	
Software filter (adjustable)	Moving average value (filter level: 30)
Step response (typ.)	60 ms (2-wire); 360 ms (3-wire); 540 ms (4-wire); 360 ms (potentiometer)
Hysteresis	adjustable via DIP switch or software
Measurement Error	
Transmission error (max.)	±1 K
Temperature coefficient	≤ 0.01 %/K
Power Supply	
Power supply type	24 VDC
Nominal supply voltage U _s	24 VDC
Supply voltage range	±30 %
Power consumption at nominal supply voltage	≤ 40 mA (+ I _{bo})
Safety and Protection	
Rated voltage of the measurement circuit connections per EN 61010-2-030	AC 300 V
Measurement category per EN/UL 61010-2-030	CAT II (input)
Note on insulation parameters	Temperature sensors are not intended for use in dangerous circuits, provided the external temperature sensors used do not have basic insulation in accordance with EN/UL 61010-1 (300 VAC; overvoltage category II; pollution degree 2). The digital output (DO) is at the potential of the supply
Protection type	IP20
Test voltage	
Test voltage (input/relay output/supply)	4 kVAC; 60 Hz; 1 min
Test voltage (input/service interface)	3 kVAC; 60 Hz; 1 min
Test voltage (relay output/service interface)	4 kVAC; 60 Hz; 1 min
Test voltage (supply/service interface)	2.5 kVAC; 60 Hz; 1 min

» DIP switch configuration, see www.wago.com

» Configuration software	Page 332
» Configuration app	Page 333
» Configuration display	Page 334
» Accessories	Page 344

Specialty Functions:



Configuration via:



Insulation parameters per EN/UL 61010-1

Line-to-neutral conductor voltage (AC) max.	300 V
Overvoltage category	II
Pollution degree	2
Insulation type (input, supply and service interface/ relay output)	Reinforced insulation
Insulation type (input/supply/service interface)	Basic insulation

Connection Data

Connection technology	Push-in CAGE CLAMP®
WAGO Connector	picoMAX® 5.0
Solid conductor	0.2 ... 2.5 mm ² / 24 ... 12 AWG
Fine-stranded conductor	0.2 ... 2.5 mm ² / 24 ... 12 AWG
Strip length	9 ... 10 mm / 0.35 ... 0.39 inch

Geometric Data

Width	12.5 mm / 0.492 inch
Height from upper-edge of DIN-rail	107 mm / 4.213 inch
Depth	110 mm / 4.331 inch

Mechanical Data

Mounting type	DIN-35 rail
---------------	-------------

Material Data

Weight	86.5 g
--------	--------

Environmental Requirements

Surrounding air temperature (operation)	-40 ... +70 °C
Surrounding air temperature (storage)	-40 ... +85 °C
Temperature range of the connecting cable according to EN 61010-2-201	≥ (T _{surrounding air} + 10 K)
Temperature range of connecting cable per UL 61010- 2-201 (min.)	90 °C

Standards and Specifications

Conformity marking	CE
EMC immunity to interference	EN 61000-6-2; EN 61326-2-3; EN 50121-3-2
EMC emission of interference	EN 61000-6-4; EN 61326-2-3; EN 50121-3-2
Standards/specifications	EN 61010-1; EN 61373

RTD Threshold Value Switch; Configurable; for Railway Applications 2857 Series

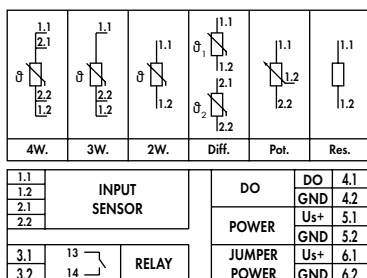

Threshold value switch; RTD sensors; Relay/1 make contact; Digital output; Supply voltage: 24 VDC; Module width: 12.5 mm

Item No.	Pack. Unit
2857-533/000-001	1

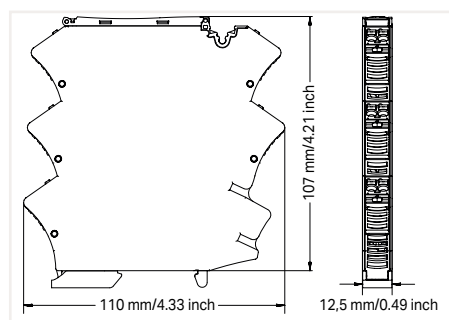

Short description:

The WAGO RTD Threshold Value Switch for RTD sensors, potentiometers and resistors monitors and reports signals for up to two switching thresholds.

Features:

- Both digital signal output and relay with make contact react to configured measurement range limits (on/off switching delay and threshold value switch function can be configured with up to two threshold values).
- Configurable RTD factor
- Adjustable software filter
- Simulation of input/output response via WAGO Configuration Display or WAGO Interface Configuration Software
- Safe 3-way isolation with 4 kV test voltage per EN 61010-1
- For railway applications

Note:

This product is supplied with 24 VDC, which can be commoned using lateral push-in type jumper bars: (6.1) US+ (BR) and (6.2) GND 2 (BR). With this variant, it is necessary to ensure that the maximum permissible total current of 2 A is not exceeded.

» Configuration software	Page 332
» Configuration display	Page 334
» Accessories	Page 344

Configuration

Configuration options	WAGO Interface Configuration Software; WAGO Configuration Display
-----------------------	--

Input

Input signal type	Resistor; RTD sensors; Potentiometers
-------------------	---------------------------------------

Input – RTD Sensors

Sensor types (RTD)	Pt100; Pt200; Pt500; Pt1000; Pt5000; Pt10000; Pt10 ... Pt20000
Sensor connection	2-wire; 3-wire; 4-wire; differential
Sensor power supply (RTD) (max.)	≤ 0.5 mA
Temperature measurement range (RTD)	-200 ... +850 °C

Input – Resistors

Input range (resistor)	0 ... 100 kΩ
Input range (potentiometer)	0 ... 100 kΩ

Output – Digital

Switching voltage (DO) (max.)	Supply voltage (applied): -0.3 V
Continuous current (DO) (max.)	100 mA (no internal restriction)
Number of switching thresholds (DO)	1 or 2 (adjustable)
Configurable rise/fall delay time (DO)	0 ... 60 s (via software)

Output – Relay

Number of make/switch-on contacts	1
Contact material (relay)	AgNi + Au
Switching voltage (max.)	250 VAC
Limiting continuous current (relay; module assembly)	6 A (≤ 60 °C); 3 A (60 ... +70 °C)
Dielectric strength, open contact (AC, 1 min)	1 kV _{rms}
Pull-in time (typ.)	8 ms
Drop-out time (typ.)	4 ms
Bounce time (typ.)	8 ms
Number of switching thresholds (relay)	1 or 2 (adjustable)
Configurable rise/fall delay time (relay)	0 ... 60 s (via software)

Signal Processing

Software filter (adjustable)	Moving average value (filter level: 30)
Step response (typ.)	60 ms (2-wire); 360 ms (3-wire); 540 ms (4-wire); 360 ms (potentiometer)

Measurement Error

Transmission error (max.)	± 1 K
Temperature coefficient	≤ 0.01 %/K

Power Supply

Power supply type	24 VDC
Nominal supply voltage U _s	24 VDC
Supply voltage range	±30 %
Power consumption at nominal supply voltage	≤ 40 mA (+ I _{DO})

Safety and Protection

Rated voltage of the measurement circuit connections per EN 61010-2-030	AC 300 V
Measurement category per EN/UL 61010-2-030	CAT II (input)
Note on insulation parameters	Temperature sensors are not intended for use in dangerous circuits, provided the external temperature sensors used do not have basic insulation in accordance with EN/UL 61010-1 (300 VAC; overvoltage category II; pollution degree 2). The digital output (DO) is at the potential of the supply
Protection type	IP20

Test voltage

Test voltage (input/relay output/supply)	4 kVAC; 60 Hz; 1 min
Test voltage (input/service interface)	3 kVAC; 60 Hz; 1 min
Test voltage (relay output/service interface)	4 kVAC; 60 Hz; 1 min
Test voltage (supply/service interface)	2.5 kVAC; 60 Hz; 1 min

Specialty Functions:



Configuration via:

**Insulation parameters per EN/UL 61010-1**

Line-to-neutral conductor voltage (AC) max.	300 V
Overvoltage category	II
Pollution degree	2
Insulation type (input, supply and service interface/ relay output)	Reinforced insulation
Insulation type (input/supply/service interface)	Basic insulation

Connection Data

Connection technology	Push-in CAGE CLAMP®
WAGO Connector	picoMAX® 5.0
Solid conductor	0.2 ... 2.5 mm² / 24 ... 12 AWG
Fine-stranded conductor	0.2 ... 2.5 mm² / 24 ... 12 AWG
Strip length	9 ... 10 mm / 0.35 ... 0.39 inch

Physical Data

Width	12.5 mm / 0.492 inch
Height from upper-edge of DIN-rail	107 mm / 4.213 inch
Depth	110 mm / 4.331 inch

Mechanical Data

Mounting type	DIN-35 rail
---------------	-------------

Material Data

Weight	86 g
--------	------

Environmental Requirements

Surrounding air temperature (operation)	-40 ... +70 °C
Surrounding air temperature (storage)	-40 ... +85 °C
Temperature range of connecting cable per EN 61010-2-201	≥ (T _{surrounding air} + 30 K)
Relative humidity	5 ... 95 %
Operating altitude (max.)	2000 m
Environmental conditions per DIN EN 50155:2018-05	
Altitude	A1
Operating temperature class	OT3
Extended operating temperature at switch-on	ST1
Quick temperature changes	H1
Power supply interruptions	S1
Power supply switching classes	C2
Service life	L4 at 40 °C (max.)
Protective coatings for populated PCBs	PC2
Temporary supply voltage dips	Criterion B

Standards and Specifications

Conformity marking	CE
EMC immunity to interference	EN 61000-6-2; EN 61326-2-3; EN 50121-3-2
EMC emission of interference	EN 61000-6-4; EN 61326-2-3; EN 50121-3-2
Standards/Specifications	EN 61010-1; EN 61373

Threshold Value Switch; Thermocouples; Configurable 2857 Series



1.1	TC+	INPUT SENSOR	DO	DO	4.1
1.2	TC-			GND	4.2
2.1	11	RELAY	POWER	Us+	5.1
2.2	12			GND	5.2
3.1	11			Us+	6.1
3.2	14			GND	6.2

Threshold Value Switch; Thermocouple; Relay/1 change-over contact; Digital output; Supply voltage: 24 VDC; Module width: 12.5 mm

Item No.	Pack. Unit
2857-534	1

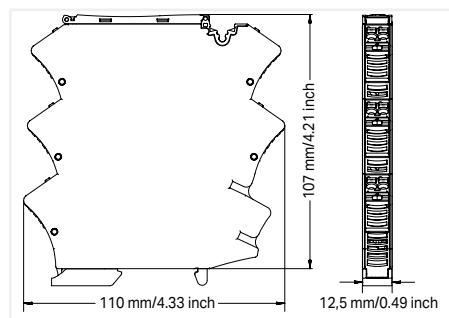

Short description:

WAGO's thermocouple threshold value switch for TC sensors monitors and reports signals of up to two switching thresholds.

Features:

- Both digital signal output and relay with changeover contact react to configured measurement range limits (on/off switching delay and threshold value switch function can be configured with up to two threshold values)
- Adjustable software filter
- Input/output response simulation via configuration display
- Safe 3-way isolation with 4 kV test voltage per EN 61140

Note:

Additional setting options via interface configuration software/app

» DIP switch configuration, see www.wago.com	
» Configuration software	Page 332
» Configuration app	Page 333
» Configuration display	Page 334
» Accessories	Page 344

Configuration

Configuration options: DIP switch; Interface configuration software; Interface configuration app; Configuration display

Input

Input signal type: TC sensors

Input – TC Sensors

Sensor types (TC): Type J, K, E, N, R, S, T, B, C
 Temperature measurement range (TC): -210 ... +1200 °C (Type J); -200 ... +1372 °C (Type K)
 Cold junction compensation: ON/OFF (default: ON)
 Cold junction error: 3 K (2 K typ.)

Output – Digital

Max. switching voltage (DO): Supply voltage applied: -0.3 V
 Max. continuous current (DO): 100 mA (no internal restriction)
 Number of switching thresholds (DO): 1 or 2 (adjustable)
 Configurable rise/fall delay time (DO): 0 ... 60 s (via software)

Output – Relay

Number of changeover/switchover contacts: 1
 Contact material (relay): AgNi + Au
 Switching voltage (max.): 250 VAC
 Limiting continuous current (relay; module assembly): 6 A (≤ 60 °C); 3 A (60 ... $+70$ °C)
 Dielectric strength, open contact (AC, 1 min): 1 kV_{rms}
 Pull-in time (typ.): 8 ms
 Drop-out time (typ.): 4 ms
 Bounce time (typ.): 8 ms
 Number of switching thresholds (relay): 1 or 2 (adjustable)
 Configurable rise/fall delay time (relay): 0 ... 60 s (via software)

Signal Processing

Software filter (adjustable): Moving average value (filter level: 30)
 Step response (typ.): 60 ms (cold junction compensation OFF); 360 ms (cold junction compensation ON)
 Hysteresis: adjustable via DIP switch or software

Measurement Error

Transmission error (max.): ± 1 K
 Temperature coefficient: ≤ 0.01 %/K

Power Supply

Power supply type: 24 VDC
 Nominal supply voltage U_s : 24 VDC
 Supply voltage range: ± 30 %
 Power consumption at nominal supply voltage: ≤ 40 mA (+ I_{DD})

Safety and Protection

Rated voltage of the measurement circuit connections per EN 61010-2-030: AC 300 V
 Measurement category per EN/UL 61010-2-030: CAT II (input)
 Note on insulation parameters: Temperature sensors are not intended for use in dangerous circuits, provided the external temperature sensors used do not have basic insulation in accordance with EN/UL 61010-1 (300 VAC; overvoltage category II; pollution degree 2). The digital output (DO) is at the potential of the supply

Protection type: IP20

Test voltage

Test voltage (input/relay output/supply): 4 kVAC; 60 Hz; 1 min
 Test voltage (input/service interface): 3 kVAC; 60 Hz; 1 min
 Test voltage (relay output/service interface): 4 kVAC; 60 Hz; 1 min
 Test voltage (supply/service interface): 2.5 kVAC; 60 Hz; 1 min

Insulation parameters per EN/UL 61010-1

Line-to-neutral conductor voltage (AC) max.: 300 V
 Overvoltage category: II
 Pollution degree: 2
 Insulation type (input, supply and service interface/relay output): Reinforced insulation
 Insulation type (input/supply/service interface): Basic insulation

Specialty Functions:



Configuration via:



Connection Data	
Connection technology	Push-in CAGE CLAMP®
WAGO Connector	picoMAX® 5.0
Solid conductor	0.2 ... 2.5 mm ² / 24 ... 12 AWG
Fine-stranded conductor	0.2 ... 2.5 mm ² / 24 ... 12 AWG
Strip length	9 ... 10 mm / 0.35 ... 0.39 inch
Geometric Data	
Width	12.5 mm / 0.492 inch
Height from upper-edge of DIN-rail	107 mm / 4.213 inch
Depth	110 mm / 4.331 inch
Mechanical Data	
Mounting type	DIN-35 rail
Material Data	
Weight	63.9 g
Environmental Requirements	
Surrounding air temperature (operation)	-40 ... +70 °C
Surrounding air temperature (storage)	-40 ... +85 °C
Temperature range of the connecting cable according to EN 61010-2-201	≥ (T _{surrounding air} + 10 K)
Temperature range of connecting cable per UL 61010-2-201 (min.)	90 °C
Standards and Specifications	
Conformity marking	CE
EMC immunity to interference	EN 61000-6-2; EN 61326-2-3; EN 50121-3-2
EMC emission of interference	EN 61000-6-4; EN 61326-2-3; EN 50121-3-2
Standards/specifications	EN 61010-1; EN 61373

Threshold Value Switch; Configurable; with Analog Input and Changeover Relay Output 857 Series

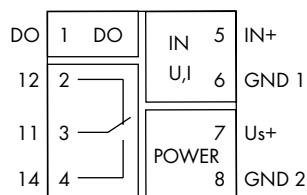

Threshold Value Switch; Analog values; Relay/1 change-over contact; Digital output; Supply voltage: 24 VDC; Module width: 6 mm

Item No.	Pack. Unit
857-531	1

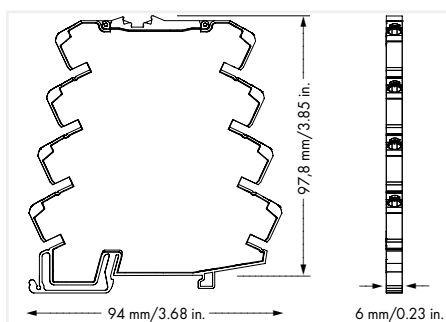

Short description:

WAGO's threshold value switch for analog signals monitors standard analog signals and reports signals exceeding a preset threshold.

Features:

- PC configuration interface
- Digital switching output
- Changeover contact relay output
- Calibrated measurement range switching
- Threshold value configuration via DIP switch and teach-in function via push/slide switch
- Safe 3-way isolation with 2.5 kV test voltage per EN 61140

Note:

Additional setting options via interface configuration software/app

Configuration

Configuration options	DIP switch; Interface configuration software; Interface configuration app; Push/slide switch
-----------------------	--

Input

Input signal type	Voltage; Current
Input signal (voltage)	± 10 V; 0 ... 30 V
Input signal (current)	± 20 mA
Input resistance (current input)	≤ 200 Ω
Input resistance (voltage input)	≥ 100 k Ω
Input current (max.)	22 mA
Input voltage (max.)	31 V

Output – Digital

Max. switching voltage (DO)	Supply voltage applied
Max. continuous current (DO)	100 mA (no internal restriction)
Number of switching thresholds (DO)	1 (adjustable)
Configurable rise/fall delay time (DO)	10 s

Output – Relay

Number of changeover/switchover contacts	1
Switching voltage (max.)	250 VAC
Limiting continuous current (relay; module assembly)	6 A (≤ 60 °C); 2 A (60 ... +70 °C)
Switching power (resistive) max.	1250 VA AC
Drop-out time (typ.)	4 ms
Number of switching thresholds (relay)	1 or 2 (adjustable)
Configurable rise/fall delay time (relay)	0 ... 30 s (via software)

Signal Processing

Step response (typ.)	16 ms
Hysteresis	adjustable via DIP switch or software

Measurement Error

Transmission error (typ.)	≤ 0.1 % of upper-range value
Temperature coefficient	≤ 0.01 %/K

Power Supply

Power supply type	24 VDC
Nominal supply voltage U_s	24 VDC
Supply voltage range	± 30 %
Power consumption at nominal supply voltage	≤ 25 mA (+ IDO)

Safety and Protection

Test voltage (input/output/supply)	2.5 kVAC; 50 Hz; 1 min
Protection type	IP20

Connection Data

Connection technology	Push-in CAGE CLAMP®
Solid conductor	0.08 ... 2.5 mm ² / 28 ... 14 AWG
Fine-stranded conductor	0.34 ... 2.5 mm ² / 22 ... 14 AWG
Strip length	9 ... 10 mm / 0.35 ... 0.39 inch

Geometric Data

Width	6 mm / 0.236 inch
Height from upper-edge of DIN-rail	97.8 mm / 3.85 inch
Depth	94 mm / 3.701 inch

Mechanical Data

Mounting type	DIN-35 rail
---------------	-------------

Material Data

Weight	38.6 g
--------	--------

Environmental Requirements

Surrounding air temperature (operation)	-25 ... +70 °C
Surrounding air temperature (storage)	-40 ... +85 °C
Relative humidity	5 ... 85 % (no condensation permissible)
Operating altitude (max.)	2000 m

Standards and Specifications

Conformity marking	CE
EMC immunity to interference	EN 61000-6-2; EN 61131-2; EN 61326-1
EMC emission of interference	EN 61000-6-4; EN 61131-2; EN 61326-1
Standards/specifications	EN 61373

» Configuration software	Page 332
» Configuration App	Page 333
» Accessories	Page 344

Specialty Functions:



Configuration via:



857-531

DIP Switch Adjustability

● = ON Default

DIP-Switch S1

Input Signal Limits ±0.25 V; ±0.5 mA				Hysteresis	
1	2	3	4	5	
					±10 V
●					0 ... 10 V
	●			●	2 ... 10 V
	●	●			0 ... 5 V
			●		1 ... 5 V
	●		●		±5 V
		●	●		0 ... 15 V
	●	●	●		0 ... 30 V
●					±20 mA
●	●				0 ... 20 mA
●		●			4 ... 20 mA
●	●	●			0 ... 10 mA
●			●		2 ... 10 mA
●	●		●		±10 mA

DIP Switch S1

Configurable Rise/Fall Delay Time in sec.			Digital Output DO Signaling	
6	7	8	9	10
				DO not active
●				● GND → U _N (switching)
	●		●	● U _N → GND (switching)
●	●			
		●		
●		●		
	●	●		
●	●	●		

Temperature Signal Conditioner; Configurable; for RTD Sensors 857 Series

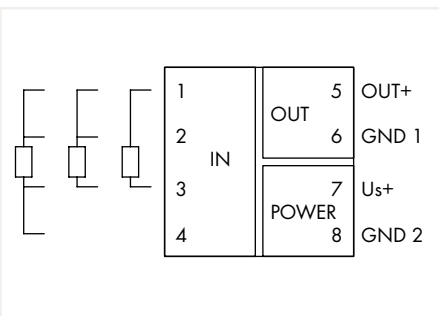

Temperature Signal Conditioner for Pt Sensors; Current and voltage output signal; Supply voltage: 24 VDC; Module width: 6 mm

Item No.	Pack. Unit
857-800	1

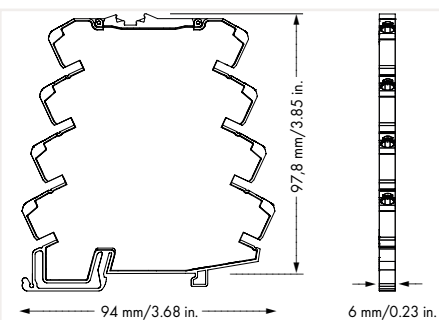

Short description:

WAGO's temperature signal conditioner records Pt100, Pt200, Pt500, and Pt1000 sensors, as well as resistors up to 4.5 kOhm, converting the temperature signal into a standard analog signal at the output.

Features:

- For Pt100, Pt200, Pt500 and Pt1000 sensors, as well as resistors up to 4.5 kOhm
- 2-, 3- and 4-wire connection technology
- Calibrated measurement range switching
- Detects sensor wire break/short circuit
- Detects measurement range underflow/overflow
- Switchable clipping
- Limitation of standard analog signal to upper range values
- Safe 3-way isolation with 2.5 kV test voltage per EN 61140

Configuration	
Configuration options	DIP switch
Input	
Input signal type	Pt sensors; Resistor
Input – RTD Sensors	
Sensor types (RTD)	Pt100; Pt200; Pt500; Pt1000
Sensor connection	2-wire; 3-wire; 4-wire (switchable)
Sensor power supply (RTD) max.	≤ 0.5 mA
Temperature measurement range (RTD)	–200 ... +850 °C
Input – Resistors	
Input range (resistor)	0 ... 1 kΩ; 0 ... 4.5 kΩ
Output	
Output signal type	Current; Voltage
Output signal (voltage)	0 ... 5 V; 1 ... 5 V; 0 ... 10 V; 2 ... 10 V
Output signal (current)	0 ... 10 mA; 2 ... 10 mA; 0 ... 20 mA; 4 ... 20 mA
Load impedance (voltage output)	≥ 2 kΩ
Load impedance (current output)	≤ 600 Ω
Signal Processing	
Step response (typ.)	180 ms (2-wire); 360 ms (3-wire)
Measurement Error	
Transmission error (typ.)	≤ 0.1 % at full measurement span
Transmission error for the set measurement range	≤ ((10 K/set measurement range [K]) + 0.1) %
Temperature coefficient	≤ 0.02 %/K
Power Supply	
Power supply type	24 VDC
Nominal supply voltage U_s	24 VDC
Supply voltage range	±30 %
Power consumption at nominal supply voltage	≤ 40 mA
Safety and Protection	
Test voltage (input/output/supply)	2.5 kVAC; 50 Hz; 1 min
Protection type	IP20
Connection Data	
Connection technology	Push-in CAGE CLAMP®
Solid conductor	0.08 ... 2.5 mm ² / 28 ... 14 AWG
Fine-stranded conductor	0.34 ... 2.5 mm ² / 22 ... 14 AWG
Strip length	9 ... 10 mm / 0.35 ... 0.39 inch
Geometric Data	
Width	6 mm / 0.236 inch
Height from upper-edge of DIN-rail	97.8 mm / 3.85 inch
Depth	94 mm / 3.701 inch
Mechanical Data	
Mounting type	DIN-35 rail
Material Data	
Weight	35.3 g
Environmental Requirements	
Surrounding air temperature (operation)	–25 ... +70 °C
Surrounding air temperature (storage)	–40 ... +85 °C
Relative humidity	5 ... 95 % (no condensation permissible)
Operating altitude (max.)	2000 m
Standards and Specifications	
Conformity marking	CE
EMC immunity to interference	EN 61000-6-2
EMC emission of interference	EN 61000-6-4

Specialty Functions:



Configuration via:



857-800

DIP Switch Adjustability

● = ON Default

DIP Switch S1

Wire Connection		Sensor Type			Output Signal					Measurement Range Underflow	Measurement Range Overflow	Wire Break	Short Circuit
1	2	3	4	5	6	7	8	9	10				
●	2 Leiter				Pt100					Lower limit of output range - 5 % *	Upper limit of output range + 2.5 % *	Upper limit of output range + 5 % *	Lower limit of output range - 12.5 % *
●	3 Leiter	●			Pt200	●				Lower limit of output range - 5 % *	Upper limit of output range + 2.5 % *	Upper limit of output range + 5 % *	Lower limit of output range - 12.5 % *
●	4 Leiter		●		Pt500		●		●	Lower limit of output range	Upper limit of output range + 2.5 %	Upper limit of output range + 5 %	Lower limit of output range
			●	●	Pt1000	●	●			Lower limit of output range	Upper limit of output range + 2.5 %	Upper limit of output range + 5 %	Lower limit of output range
				●	1 kΩ		●		●	Lower limit of output range	Upper limit of output range	Upper limit of output range + 5 %	Upper limit of output range + 5 %
			●	●	4,5 kΩ	●	●			Lower limit of output range	Upper limit of output range	Upper limit of output range + 5 %	Upper limit of output range + 5 %
							●	●		Lower limit of output range	Upper limit of output range	Lower limit of output range	Lower limit of output range
							●	●	●	Lower limit of output range	Upper limit of output range	Lower limit of output range	Lower limit of output range
							●	●	●	Lower limit of output range	Upper limit of output range	Lower limit of output range	Lower limit of output range

* acc. to NAMUR NE 43

DIP Switch S2

Start Temperature				End Temperature																																	
1	2	3	4	°C	°F	5	6	7	8	9	10	°C	°F	5	6	7	8	9	10	°C	°F	5	6	7	8	9	10	°C	°F								
				0	32							100	212							●	75	167						●	210	410				●	●	475	887
●				-200	-328	●						0	32	●						●	80	176	●				●	220	428	●			●	●	500	932	
●	●			-175	-283		●					5	41		●					●	85	185		●			●	230	446		●		●	●	525	997	
●	●	●		-150	-238	●	●					10	50	●	●					●	90	194	●	●			●	240	464	●	●		●	●	550	1022	
	●			-125	-193			●				15	59			●				●	95	203			●		●	250	482			●	●	●	575	1067	
●	●			-100	-148	●	●					20	68	●		●				●	100	212	●	●			●	260	500	●		●	●	●	600	1112	
	●	●		-90	-130		●	●				25	77		●	●				●	110	230		●	●		●	270	518		●	●	●	●	625	1157	
●	●	●		-80	-112	●	●	●				30	86	●	●	●				●	120	248	●	●	●		●	280	536	●	●	●	●	●	650	1202	
		●		-70	-94			●				35	95				●	●		●	130	266			●		●	290	554			●	●	●	675	1247	
●		●		-60	-76	●		●				40	104	●			●	●		●	140	284	●		●		●	300	572	●		●	●	●	700	1292	
	●	●		-50	-58		●	●				45	113		●		●	●		●	150	302		●	●		●	325	617		●	●	●	●	725	1337	
●	●		●	-40	-40	●	●	●				50	122	●	●		●	●		●	160	320	●	●		●	●	350	662	●	●	●	●	●	750	1382	
		●	●	-30	-22			●	●			55	131			●	●	●		●	170	338			●	●	●	375	707			●	●	●	775	1427	
●		●	●	-20	-4	●		●	●			60	140	●			●	●		●	180	356	●	●	●		●	400	752	●		●	●	●	800	1472	
	●	●	●	-10	14			●	●	●		65	149			●	●	●	●	●	190	374		●	●	●	●	425	797			●	●	●	825	1517	
●	●	●	●	0	32	●	●	●	●			70	158	●	●	●	●	●	●	●	200	392	●	●	●	●	●	450	842	●	●	●	●	●	850	1562	

The minimum distance from the start temperature to the end temperature may not fall short of 50K degrees on the Celsius (C) scale or 122K degrees on the Fahrenheit (F) scale.

Temperature Signal Conditioner; Configurable; for RTD Sensors 857 Series

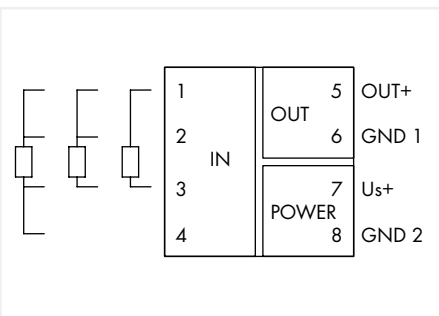

Temperature Signal Conditioner for Pt Sensors; Current and voltage output signal; Supply voltage: 24 VDC; Module width: 6 mm

Item No.	Pack. Unit
857-801	1

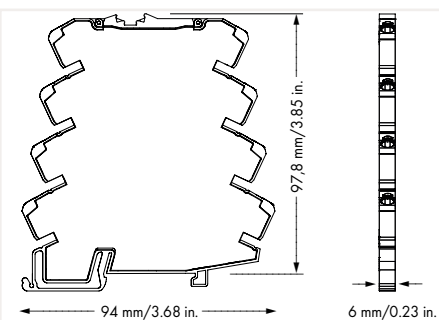

Short description:

WAGO's temperature signal conditioner records Pt100, Pt200, Pt500, and Pt1000 sensors, as well as resistors up to 4.5 kOhm, converting the temperature signal into a standard analog signal at the output.

Features:

- PC configuration interface
- For Pt100, Pt200, Pt500 and Pt1000 sensors, as well as resistors up to 4.5 kOhm
- 2-, 3- and 4-wire connection technology
- Detects calibrated measurement range switching
- Detects sensor wire break/short circuit
- Measurement range underflow/overflow
- Switchable clipping
- Limitation of standard analog signal to upper range values
- Safe 3-way isolation with 2.5 kV test voltage per EN 61140

Note:

Additional setting options as well as output signal inversion via interface configuration software or interface configuration app

Configuration	
Configuration options	DIP switch; Interface configuration software; Interface configuration app
Input	
Input signal type	Pt sensors; Resistor
Input – RTD Sensors	
Sensor types (RTD)	Pt100; Pt200; Pt500; Pt1000
Sensor connection	2-wire, 3-wire, 4-wire (switchable)
Sensor power supply (RTD) max.	≤ 0.5 mA
Temperature measurement range (RTD)	–200 ... +850 °C
Measurement span (RTD) min.	50 K
Input – Resistors	
Input range (resistor)	0 ... 1 kΩ; 0 ... 4.5 kΩ
Measurement span (min.)	50 Ω
Output	
Output signal type	Current; Voltage
Output signal (voltage)	0 ... 5 V; 1 ... 5 V; 0 ... 10 V; 2 ... 10 V
Output signal (current)	0 ... 10 mA; 2 ... 10 mA; 0 ... 20 mA; 4 ... 20 mA
Load impedance (voltage output)	≥ 2 kΩ
Load impedance (current output)	≤ 600 Ω
Signal Processing	
Step response (typ.)	180 ms (2-wire); 360 ms (3-wire)
Measurement Error	
Transmission error (typ.)	≤ 0.1 % at full measurement span
Transmission error for the set measurement range	≤ ((10 K/set measurement range [K]) + 0.1) %
Temperature coefficient	≤ 0.02 %/K
Power Supply	
Power supply type	24 VDC
Nominal supply voltage U_s	24 VDC
Supply voltage range	±30 %
Power consumption at nominal supply voltage	≤ 40 mA
Safety and Protection	
Test voltage (input/output/supply)	2.5 kVAC; 50 Hz; 1 min
Protection type	IP20
Connection Data	
Connection technology	Push-in CAGE CLAMP®
Solid conductor	0.08 ... 2.5 mm ² / 28 ... 14 AWG
Fine-stranded conductor	0.34 ... 2.5 mm ² / 22 ... 14 AWG
Strip length	9 ... 10 mm / 0.35 ... 0.39 inch
Geometric Data	
Width	6 mm / 0.236 inch
Height from upper-edge of DIN-rail	97.8 mm / 3.85 inch
Depth	94 mm / 3.701 inch
Mechanical Data	
Mounting type	DIN-35 rail
Material Data	
Weight	35.1 g
Environmental Requirements	
Surrounding air temperature (operation)	–25 ... +70 °C
Surrounding air temperature (storage)	–40 ... +85 °C
Relative humidity	5 ... 95 % (no condensation permissible)
Operating altitude (max.)	2000 m
Standards and Specifications	
Conformity marking	CE
EMC immunity to interference	EN 61000-6-2
EMC emission of interference	EN 61000-6-4

» Configuration software	Page 332
» Configuration App	Page 333
» Accessories	Page 344

Specialty Functions:



Configuration via:



857-801

DIP Switch Adjustability

● = ON Default

DIP Switch S1

Wire Connection		Sensor Type			Output Signal					Measurement Range Underflow	Measurement Range Overflow	Wire Break	Short Circuit
1	2	3	4	5	6	7	8	9	10				
●	2-wire	●			Pt100	●				Lower limit of output range - 5 % *	Upper limit of output range + 2.5 % *	Upper limit of output range + 5 % *	Lower limit of output range - 12.5 % *
●	3-wire	●			Pt200	●				Lower limit of output range	Upper limit of output range + 2.5 %	Upper limit of output range + 5 %	Lower limit of output range
●	4-wire	●	●		Pt500	●	●		●	Lower limit of output range	Upper limit of output range + 2.5 %	Upper limit of output range + 5 %	Lower limit of output range
		●	●		Pt1000	●	●		●	Lower limit of output range	Upper limit of output range	Upper limit of output range + 5 %	Upper limit of output range + 5 %
			●		1 kΩ	●	●		●	Lower limit of output range	Upper limit of output range	Upper limit of output range + 5 %	Upper limit of output range + 5 %
			●	●	4.5 kΩ	●	●		●	Lower limit of output range	Upper limit of output range	Lower limit of output range	Lower limit of output range
						●	●		●	Lower limit of output range	Upper limit of output range	Lower limit of output range	Lower limit of output range
						●	●		●	Lower limit of output range	Upper limit of output range	Lower limit of output range	Lower limit of output range
						●	●		●	Lower limit of output range	Upper limit of output range	Lower limit of output range	Lower limit of output range

* acc. to NAMUR NE 43

DIP Switch S2

Start Temperature				End Temperature																																	
1	2	3	4	°C	°F	5	6	7	8	9	10	°C	°F	5	6	7	8	9	10	°C	°F	5	6	7	8	9	10	°C	°F								
				0	32							100	212								75	167							210	410					475	887	
●				-200	-328	●						0	32	●							80	176	●						220	428	●				500	932	
●	●			-175	-283	●						5	41	●							85	185	●						230	446	●				525	997	
●	●	●		-150	-238	●	●					10	50	●	●						90	194	●	●					240	464	●	●			550	1022	
	●			-125	-193		●					15	59			●					95	203			●				250	482			●		575	1067	
●	●			-100	-148	●	●					20	68	●		●					100	212	●		●				260	500	●		●		600	1112	
	●	●		-90	-130	●	●					25	77		●	●					110	230		●	●				270	518		●	●		625	1157	
●	●	●		-80	-112	●	●	●				30	86	●	●	●					120	248	●	●	●				280	536	●	●	●		650	1202	
		●		-70	-94			●				35	95				●	●			130	266				●			290	554			●	●	675	1247	
●		●		-60	-76	●		●				40	104	●			●	●			140	284	●			●			300	572	●		●	●	700	1292	
	●	●		-50	-58		●	●				45	113		●		●	●			150	302		●		●			325	617		●	●	●	725	1337	
●	●		●	-40	-40	●	●	●				50	122	●	●		●	●			160	320	●	●		●			350	662	●	●	●	●	750	1382	
		●	●	-30	-22			●	●			55	131			●	●	●			170	338			●	●			375	707			●	●	●	775	1427
●		●	●	-20	-4	●		●	●			60	140	●			●	●			180	356	●	●	●				400	752	●		●	●	800	1472	
	●	●	●	-10	14			●	●	●		65	149		●	●	●	●			190	374		●	●	●			425	797		●	●	●	825	1517	
●	●	●	●	0	32	●	●	●	●			70	158	●	●	●	●	●			200	392	●	●	●	●			450	842	●	●	●	●	850	1562	

The minimum distance from the start temperature to the end temperature may not fall short of 50K degrees on the Celsius (C) scale or 122K degrees on the Fahrenheit (F) scale.

Temperature Signal Conditioner; Configurable; for RTD Sensors 857 Series

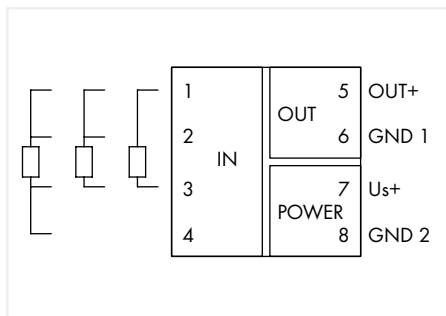

Temperature Signal Conditioner for RTD Sensors; Current and voltage output signal; Supply voltage: 24 VDC; Module width: 6 mm

Item No.	Pack. Unit
857-808	1

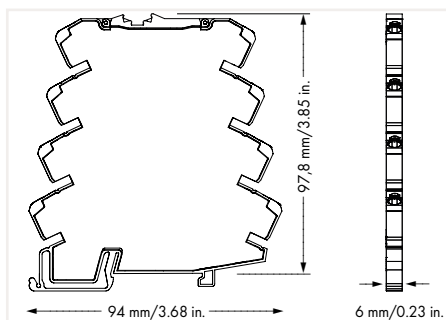

Short description:

WAGO's temperature signal conditioner records signals from Pt46 and Cu53 sensors and converts the temperature signal into a standard analog signal at the output.

Features:

- 2-, 3- and 4-wire connection technology
- Calibrated measurement range switching
- Detects sensor wire break/short circuit
- Detects measurement range underflow/overflow
- Clipping function limits the standard analog signal to the upper range values
- Safe 3-way isolation with 2.5 kV test voltage per EN 61140

Configuration via:



Configuration	
Configuration options	DIP switch
Input	
Input signal type	Pt sensors; Cu sensors
Input – RTD Sensors	
Sensor types (RTD)	Pt46; Cu53
Sensor connection	2-wire, 3-wire, 4-wire (switchable)
Sensor power supply (RTD) max.	≤ 0.5 mA
Temperature measurement range (RTD)	-200 ... +300 °C (Pt46); 0 ... +180 °C (Cu53)
Measurement span (RTD) min.	50 K
Output	
Output signal type	Current; Voltage
Output signal (voltage)	0 ... 5 V; 1 ... 5 V; 0 ... 10 V; 2 ... 10 V
Output signal (current)	0 ... 10 mA; 2 ... 10 mA; 0 ... 20 mA; 4 ... 20 mA
Load impedance (voltage output)	≥ 2 kΩ
Load impedance (current output)	≤ 600 Ω
Signal Processing	
Step response (typ.)	180 ms (2-wire); 360 ms (3-wire)
Measurement Error	
Transmission error (typ.)	≤ 0.1 % at full measurement span
Transmission error for the set measurement range	≤ ((10 K/set measurement range [K]) + 0.1) %
Temperature coefficient	≤ 0.02 %/K
Power Supply	
Power supply type	24 VDC
Nominal supply voltage U_s	24 VDC
Supply voltage range	±30 %
Power consumption at nominal supply voltage	≤ 40 mA
Safety and Protection	
Test voltage (input/output/supply)	2.5 kVAC; 50 Hz; 1 min
Protection type	IP20
Connection Data	
Connection technology	Push-in CAGE CLAMP®
Solid conductor	0.08 ... 2.5 mm ² / 28 ... 14 AWG
Fine-stranded conductor	0.34 ... 2.5 mm ² / 22 ... 14 AWG
Strip length	9 ... 10 mm / 0.35 ... 0.39 inch
Geometric Data	
Width	6 mm / 0.236 inch
Height from upper-edge of DIN-rail	97.8 mm / 3.85 inch
Depth	94 mm / 3.701 inch
Mechanical Data	
Mounting type	DIN-35 rail
Material Data	
Weight	35.4 g
Environmental Requirements	
Surrounding air temperature (operation)	-25 ... +70 °C
Surrounding air temperature (storage)	-40 ... +85 °C
Relative humidity	5 ... 95 % (no condensation permissible)
Operating altitude (max.)	2000 m
Standards and Specifications	
Conformity marking	CE
EMC immunity to interference	EN 61000-6-2
EMC emission of interference	EN 61000-6-4

857-808

DIP Switch Adjustability

● = ON Default

DIP Switch S1

Wire Connection		Sensor Type			Output Signal							Measurement Range Underflow	Measurement Range Overflow	Wire Break	Short Circuit
1	2	3	4	5	6	7	8		9	10					
	2-wire				Pt46							Lower limit of output range - 5 % *	Upper limit of output range + 2.5 % *	Upper limit of output range + 5 % *	Lower limit of output range - 12.5 % *
●	3-wire	●			Cu53	●						Lower limit of output range	Upper limit of output range + 2.5 %	Upper limit of output range + 5 %	Lower limit of output range
	4-wire								●			Lower limit of output range	Upper limit of output range	Upper limit of output range + 5 %	Upper limit of output range + 5 %
										●		Lower limit of output range	Upper limit of output range	Upper limit of output range + 5 %	Lower limit of output range
										●		Lower limit of output range	Upper limit of output range	Lower limit of output range	Lower limit of output range

* acc. to NAMUR NE 43

DIP Switch S2

Start Temperature										End Temperature																			
1	2	3	4	°C	°F	5	6	7	8	9	10	°C	°F	5	6	7	8	9	10	°C	°F	5	6	7	8	9	10	°C	°F
				0	32							100	212							●	75	167					●	210	410
●				-200	-328	●						0	32	●						●	80	176	●				●	220	428
	●			-175	-283		●					5	41		●					●	85	185		●			●	230	446
●	●			-150	-238	●	●					10	50	●	●					●	90	194	●	●			●	240	464
		●		-125	-193			●				15	59			●				●	95	203			●		●	250	482
●	●			-100	-148	●	●					20	68	●	●	●				●	100	212	●	●			●	260	500
	●	●		-90	-130		●	●				25	77		●	●	●			●	110	230		●	●		●	270	518
●	●	●		-80	-112	●	●	●				30	86	●	●	●				●	120	248	●	●	●		●	280	536
			●	-70	-94				●			35	95							●	130	266				●	●	290	554
●			●	-60	-76	●			●			40	104	●						●	140	284	●			●	●	300	572
	●		●	-50	-58		●		●			45	113		●					●	150	302							
●	●		●	-40	-40	●	●		●			50	122	●	●					●	160	320							
		●	●	-30	-22			●	●			55	131			●	●	●		●	170	338							
●		●	●	-20	-4	●		●	●			60	140	●		●	●	●		●	180	356							
	●	●	●	-10	14		●	●	●			65	149		●	●	●	●		●	190	374							
●	●	●	●	0	32	●	●	●	●			70	158	●	●	●	●	●		●	200	392							

Temperature Signal Conditioner; Configurable; for Thermocouples 857 Series

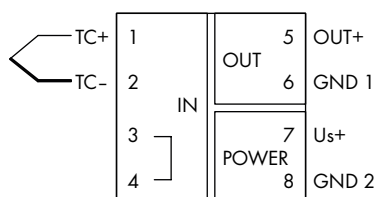

Temperature Signal Conditioner for Thermocouples;
Current and voltage output signal; Supply voltage:
24 VDC; Module width: 6 mm

Item No.	Pack. Unit
857-810	1

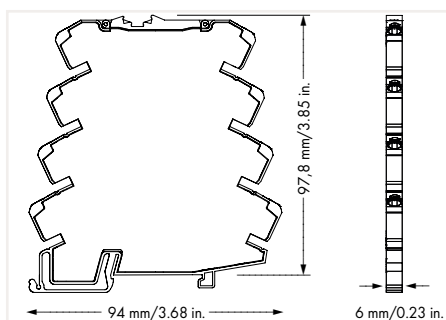

Short description:

WAGO's temperature signal conditioner records signals from thermocouples (type J, K) and converts the temperature signal into a standard analog signal at the output.

Features:

- For type J and K thermocouples
- Cold junction compensation (ON/OFF)
- Calibrated measurement range switching
- Detects a sensor wire break
- Detects measurement range underflow/overflow
- Switchable clipping
- Limitation of standard analog signal to upper range values
- Safe 3-way isolation with 2.5 kV test voltage per EN 61140

Specialty Functions:



Configuration via:



Configuration	
Configuration options	DIP switch
Input	
Input signal type	TC sensors
Input – TC Sensors	
Sensor types (TC)	Type J; Type K
Temperature measurement range (TC)	-150 ... +1200 °C (Type J); -150 ... +1350 °C (Type K)
Measurement min. (TC)	100 K
Cold junction compensation	ON/OFF (default: ON)
Cold junction error	3 K (2 K typ.)
Output	
Output signal type	Current; Voltage
Output signal (voltage)	0 ... 5 V; 1 ... 5 V; 0 ... 10 V; 2 ... 10 V
Output signal (current)	0 ... 10 mA; 2 ... 10 mA; 0 ... 20 mA; 4 ... 20 mA
Load impedance (voltage output)	≥ 2 kΩ
Load impedance (current output)	≤ 600 Ω
Signal Processing	
Step response (typ.)	60 ms (cold junction compensation OFF); 120 ms (cold junction compensation ON)
Measurement Error	
Transmission error (typ.)	≤ 0.1% at max. measurement span (type J, K)
Transmission error for the set measurement range	≤ (150 K/set measurement range [K]) %
Temperature coefficient	≤ 0.04 %/K
Power Supply	
Power supply type	24 VDC
Nominal supply voltage U_s	24 VDC
Supply voltage range	±30 %
Power consumption at nominal supply voltage	≤ 40 mA
Safety and Protection	
Test voltage (input/output/supply)	2.5 kVAC; 50 Hz; 1 min
Protection type	IP20
Connection Data	
Connection technology	Push-in CAGE CLAMP®
Solid conductor	0.08 ... 2.5 mm ² / 28 ... 14 AWG
Fine-stranded conductor	0.34 ... 2.5 mm ² / 22 ... 14 AWG
Strip length	9 ... 10 mm / 0.35 ... 0.39 inch
Geometric Data	
Width	6 mm / 0.236 inch
Height from upper-edge of DIN-rail	97.8 mm / 3.85 inch
Depth	94 mm / 3.701 inch
Mechanical Data	
Mounting type	DIN-35 rail
Material Data	
Weight	35.5 g
Environmental Requirements	
Surrounding air temperature (operation)	-25 ... +70 °C
Surrounding air temperature (storage)	-40 ... +85 °C
Relative humidity	5 ... 95 % (no condensation permissible)
Operating altitude (max.)	2000 m
Standards and Specifications	
Conformity marking	CE
EMC immunity to interference	EN 61000-6-2
EMC emission of interference	EN 61000-6-4

Temperature Signal Conditioner; Configurable; for Thermocouples 857 Series

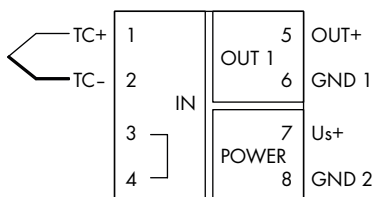
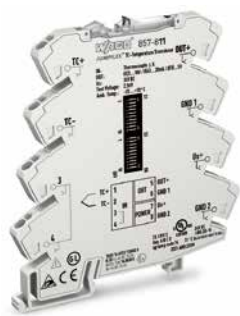

Temperature Signal Conditioner for Thermocouples;
Current and voltage output signal; Supply voltage:
24 VDC; Module width: 6 mm

Item No.	Pack. Unit
857-811	1

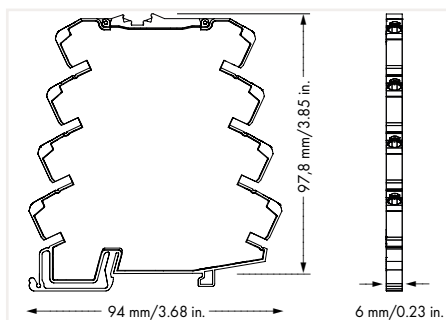

Short description:

WAGO's temperature signal conditioner records signals from thermocouples of type J and K (E, R, N, S, T, B, C) and converts the temperature signal into a standard analog signal.

Features:

- PC configuration interface
- For thermocouples of type J and K (E, R, N, S, T, B, C)
- Cold junction compensation (ON/OFF)
- Calibrated measurement range switching
- Detects a sensor wire break
- Detects measurement range underflow/overflow
- Switchable clipping
- Limitation of standard analog signal to upper range values
- Safe 3-way isolation with 2.5 kV test voltage per EN 61140

Note:

Additional setting options as well as output signal inversion via interface configuration software or interface configuration app

Configuration	
Configuration options	DIP switch; Interface configuration software; Interface configuration app

Input	
Input signal type	TC sensors

Input – TC Sensors	
Sensor types (TC)	Type J; Type K
Temperature measurement range (TC)	-150 ... +1200 °C (Type J); -150 ... +1350 °C (Type K)
Measurement min. (TC)	100 K
Cold junction compensation	ON/OFF (default: ON)
Cold junction error	3 K (2 K typ.)

Output	
Output signal type	Current; Voltage
Output signal (voltage)	0 ... 5 V; 1 ... 5 V; 0 ... 10 V; 2 ... 10 V
Output signal (current)	0 ... 10 mA; 2 ... 10 mA; 0 ... 20 mA; 4 ... 20 mA
Load impedance (voltage output)	≥ 2 kΩ
Load impedance (current output)	≤ 600 Ω

Signal Processing	
Step response (typ.)	60 ms (cold junction compensation OFF); 120 ms (cold junction compensation ON)

Measurement Error	
Transmission error (typ.)	≤ 0.1% at max. measurement span (type J, K)
Transmission error for the set measurement range	≤ (150 K/set measurement range [K]) %
Temperature coefficient	≤ 0.04 %/K

Power Supply	
Power supply type	24 VDC
Nominal supply voltage U_s	24 VDC
Supply voltage range	±30 %
Power consumption at nominal supply voltage	≤ 40 mA

Safety and Protection	
Test voltage (input/output/supply)	2.5 kVAC; 50 Hz; 1 min
Protection type	IP20

Connection Data	
Connection technology	Push-in CAGE CLAMP®
Solid conductor	0.08 ... 2.5 mm ² / 28 ... 14 AWG
Fine-stranded conductor	0.34 ... 2.5 mm ² / 22 ... 14 AWG
Strip length	9 ... 10 mm / 0.35 ... 0.39 inch

Geometric Data	
Width	6 mm / 0.236 inch
Height from upper-edge of DIN-rail	97.8 mm / 3.85 inch
Depth	94 mm / 3.701 inch

Mechanical Data	
Mounting type	DIN-35 rail

Material Data	
Weight	36 g

Environmental Requirements	
Surrounding air temperature (operation)	-25 ... +70 °C
Surrounding air temperature (storage)	-40 ... +85 °C
Relative humidity	5 ... 95 % (no condensation permissible)
Operating altitude (max.)	2000 m

Standards and Specifications	
Conformity marking	CE
EMC immunity to interference	EN 61000-6-2
EMC emission of interference	EN 61000-6-4

» Configuration software	Page 332
» Configuration App	Page 333
» Accessories	Page 344

Temperature Signal Conditioner; Configurable; for Thermocouples 857 Series

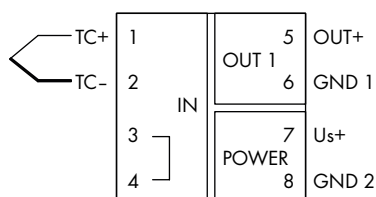

Temperature Signal Conditioner for Thermocouples;
Current and voltage output signal; Supply voltage:
24 VDC; Module width: 6 mm

Item No.	Pack. Unit
857-812	1

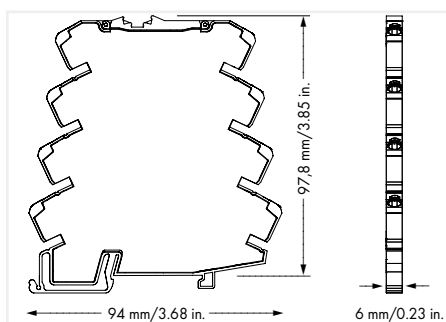

Short description:

WAGO's temperature signal conditioner records signals from thermocouples (type K, S, B, R) and converts the temperature signal into a standard analog signal at the output.

Features:

- For thermocouples of type K, S, B and R
- Cold junction compensation (ON/OFF)
- Calibrated measurement range switching
- Detects a sensor wire break
- Detects measurement range underflow/overflow
- Clipping function limits the standard analog signal to the upper range values
- Safe 3-way isolation with 2.5 kV test voltage per EN 61140

Configuration via:



Configuration	
Configuration options	DIP switch
Input	
Input signal type	TC sensors
Input – TC Sensors	
Sensor types (TC)	Type K, S, B, R
Temperature measurement range (TC)	0 ... +1200 °C (Type K); 0 ... +1600 °C (Type S); 600 ... +1800 °C (Type B); 0 ... +1600 °C (Type R)
Cold junction compensation	ON/OFF (default: ON)
Cold junction error	3 K (2 K typ.)
Output	
Output signal type	Current; Voltage
Output signal (voltage)	0 ... 5 V; 1 ... 5 V; 0 ... 10 V; 2 ... 10 V
Output signal (current)	0 ... 10 mA; 2 ... 10 mA; 0 ... 20 mA; 4 ... 20 mA
Load impedance (voltage output)	≥ 2 kΩ
Load impedance (current output)	≤ 600 Ω
Signal Processing	
Step response (typ.)	60 ms (cold junction compensation OFF); 120 ms (cold junction compensation ON)
Measurement Error	
Transmission error (typ.)	≤ 0.1 % at full measurement span
Transmission error for the set measurement range	≤ (150 K/set measurement range [K]) %
Temperature coefficient	≤ 0.04 %/K
Power Supply	
Power supply type	24 VDC
Nominal supply voltage U_s	24 VDC
Supply voltage range	±30 %
Power consumption at nominal supply voltage	≤ 40 mA
Safety and Protection	
Test voltage (input/output/supply)	2.5 kVAC; 50 Hz; 1 min
Protection type	IP20
Connection Data	
Connection technology	Push-in CAGE CLAMP®
Solid conductor	0.08 ... 2.5 mm ² / 28 ... 14 AWG
Fine-stranded conductor	0.34 ... 2.5 mm ² / 22 ... 14 AWG
Strip length	9 ... 10 mm / 0.35 ... 0.39 inch
Geometric Data	
Width	6 mm / 0.236 inch
Height from upper-edge of DIN-rail	97.8 mm / 3.85 inch
Depth	94 mm / 3.701 inch
Mechanical Data	
Mounting type	DIN-35 rail
Material Data	
Weight	35.7 g
Environmental Requirements	
Surrounding air temperature (operation)	-25 ... +70 °C
Surrounding air temperature (storage)	-40 ... +85 °C
Relative humidity	5 ... 95 % (no condensation permissible)
Operating altitude (max.)	2000 m
Standards and Specifications	
Conformity marking	CE
EMC immunity to interference	EN 61000-6-2
EMC emission of interference	EN 61000-6-4

857-812

DIP Switch Adjustability

● = ON Default

DIP Switch S1

Cold Junction Compensation		Sensor Type		Output Signal						Measurement Range Underflow	Measurement Range Overflow	Wire Break
1		2	3	4	5	6	7	8				
●	Ein			K					0 ... 20 mA	Lower limit of output range - 5 % *	Upper limit of output range + 2.5 % *	Upper limit of output range + 5 % *
	Aus	●		S	●				4 ... 20 mA	Lower limit of output range	Upper limit of output range + 2.5 %	Upper limit of output range + 5 %
			●	B		●			0 ... 10 mA	Lower limit of output range	Upper limit of output range	Upper limit of output range + 5 %
			● ●	R	● ●				2 ... 10 mA	Lower limit of output range	Upper limit of output range	Upper limit of output range + 5 %
						●			0 ... 10 V	Lower limit of output range	Upper limit of output range	Upper limit of output range + 5 %
					●	●			2 ... 10 V	Lower limit of output range	Upper limit of output range	Upper limit of output range + 5 %
						● ●			0 ... 5 V	Lower limit of output range	Upper limit of output range	Lower limit of output range
					● ● ●				1 ... 5 V	Lower limit of output range	Upper limit of output range	Lower limit of output range

DIP Switch S1 (9) n.c.

* acc. to NAMUR NE 43

DIP Switch S1+S2

Start Temperature					End Temperature																
S1	S2				°C	°F	S2				°C	°F	S2				°C	°F			
10	1	2	3	4			5	6	7	8			9	10	5	6			7	8	9
					0	32						1000	1832	●		●		●		1000	1832
●					50	122	●					0	32		●	●		●		1050	1922
	●				100	212		●				50	122	●	●	●		●		1100	2012
●	●				150	302	●	●				100	212				●	●		1150	2102
		●			200	392			●			150	302	●			●	●		1200	2192
●		●			250	482	●		●			200	392		●		●	●		1250	2282
	●	●			300	572		●	●			250	482	●	●		●	●		1300	2372
●	●	●			350	662	●	●	●			300	572			●	●	●		1350	2462
			●		400	752				●		350	662	●		●	●	●		1400	2552
●			●		450	842	●			●		400	752		●	●	●	●		1450	2642
	●		●		500	932		●		●		450	842	●	●	●	●	●		1500	2732
●	●		●		550	1022	●	●		●		500	932						●	1550	2822
		●	●		600	1112			●	●		550	1022	●					●	1600	2912
●		●	●		650	1202	●		●	●		600	1112		●				●	1650	3002
	●	●	●		700	1292		●	●	●		650	1202	●	●				●	1700	3092
●	●	●	●		750	1382	●	●	●	●		700	1292			●			●	1750	3182
			●		800	1472					●	750	1382	●		●			●	1800	3272
●			●		850	1562	●			●		800	1472								
	●		●		900	1652		●		●		850	1562								
●	●		●		950	1742	●	●		●		900	1652								
		●	●		1000	1832			●	●		950	1742								

3

Temperature Signal Conditioner; Configurable; for RTD Sensors 857 Series

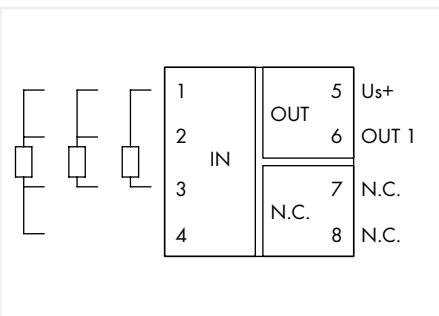

Temperature Signal Conditioner for RTD Sensors;
Current and voltage output signal; Loop-powered RTD;
Module width: 6 mm

Item No.	Pack. Unit
857-815	1

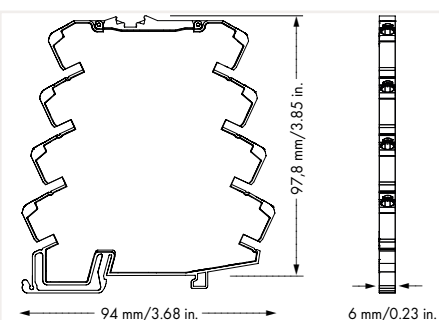

Short description:

WAGO's loop-powered RTD temperature signal conditioner records sensors (Pt100, Pt200, Pt500, Pt1000) and resistors up to 4.5 k Ω , converting the temperature signal into a standard analog signal at the output. The loop-powered RTD temperature signal conditioner provides safe isolation between input and output with 3 kV test voltage per EN 61010-1.

Features:

- No additional supply voltage required
- For Pt100, Pt200, Pt500 and Pt1000 sensors, as well as resistors up to 4.5 k Ω
- 2-, 3- and 4-wire connection technology
- Calibrated measurement range switching
- Detects sensor wire break/short circuit
- Safe 2-way isolation with 2.5 kV test voltage per EN 61010-1

Configuration via:



Configuration	
Configuration options	DIP switches
Input	
Input signal type	Pt sensors; resistor
Input current (max.)	50 mA
Input voltage (max.)	30 VDC
Input – RTD Sensors	
Sensor types (RTD)	Pt100; Pt200; Pt500; Pt1000
Sensor connection	2-wire, 3-wire, 4-wire (switchable)
Sensor power supply (RTD) max.	≤ 0.5 mA
Temperature measurement range (RTD)	-200 ... +850 °C
Measurement span (RTD) min.	50 K
Input – Resistors	
Input range (resistor)	0 ... 1 k Ω ; 0 ... 4.5 k Ω
Output	
Output signal type	Current
Output signal (current)	4 ... 20 mA; 20 ... 4 mA
Load impedance (current output)	See derating graph
Signal Processing	
Step response (typ.)	1000 ms
Measurement Error	
Transmission error (typ.)	≤ 0.1 % at full measurement span
Transmission error for the set measurement range	$\leq ((40 \text{ K}/\text{set measurement range [K]}) + 0.1)$ %
Temperature coefficient	≤ 0.02 %/K
Power Supply	
Power supply type	loop-powered (via output)
Supply voltage	8 ... 30 VDC (power derived from the output circuit)
Safety and Protection	
Measurement category per EN/UL 61010-2-030	CAT II (input)
Protection type	IP20
Test voltage	
Test voltage (input/analog output)	3 kVAC; 50 ... 60 Hz; 1 min
Insulation parameters per EN/UL 61010-1	
Line-to-neutral conductor voltage (AC) max.	150 V
Overvoltage category	II
Pollution degree	2
Insulation type (input/analog output)	Reinforced insulation
Connection Data	
Connection technology	Push-in CAGE CLAMP®
Solid conductor	0.08 ... 2.5 mm ² / 28 ... 14 AWG
Fine-stranded conductor	0.34 ... 2.5 mm ² / 22 ... 14 AWG
Strip length	9 ... 10 mm / 0.35 ... 0.39 inch
Geometric Data	
Width	6 mm / 0.236 inch
Height from upper-edge of DIN-rail	97.8 mm / 3.85 inch
Depth	94 mm / 3.701 inch
Mechanical Data	
Mounting type	DIN-35 rail
Material Data	
Weight	38.9 g
Environmental Requirements	
Surrounding air temperature (operation)	-25 ... +70 °C (at nominal current)
Surrounding air temperature (storage)	-40 ... +85 °C
Temperature range of the connecting cable according to EN 61010-2-201	$\geq (T_{\text{surrounding air}} + 10 \text{ K})$
Temperature range of connecting cable per UL 61010-2-201 (min.)	90 °C
Relative humidity	5 ... 95 % (no condensation permissible)
Operating altitude (max.)	2000 m

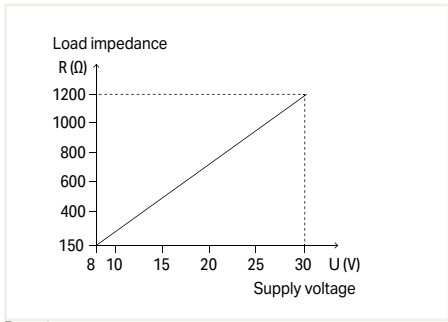

Derating

Standards and Specifications	
Conformity marking	CE
EMC immunity to interference	EN 61000-6-2; EN 61326-1; EN 50121-3-2
EMC emission of interference	EN 61000-6-3; EN 61326-1; EN 50121-3-2
Standards/specifications	EN 61010-1; EN 61373

857-815

DIP Switch Adjustability

● = ON Default

DIP Switch S1

Sensor Connection		Sensor Type			Output Signal		N.C.		Measurement Range Underflow	Measurement Range Overflow	Wire Break	Short Circuit	
1	2	3	4	5	6	7	8	9	10				
●	2-wire			Pt100	4 ... 20 mA					Lower limit of output range - 5 % *	Upper limit of output range + 2.5 % *	Upper limit of output range + 5 % *	Lower limit of output range - 12.5 % *
●	3-wire	●		Pt200	20 ... 4 mA					Lower limit of output range	Upper limit of output range + 2.5 %	Upper limit of output range + 5 %	Lower limit of output range
●	4-wire		●	Pt500				●		Lower limit of output range	Upper limit of output range	Upper limit of output range + 5 %	Lower limit of output range
●	2-wire	●	●	Pt1000					●	Lower limit of output range	Upper limit of output range	Upper limit of output range + 5 %	Upper limit of output range + 5 %
				1 kΩ					●	Lower limit of output range	Upper limit of output range	Upper limit of output range + 5 %	Upper limit of output range + 5 %
			●	4,5 kΩ					●	Lower limit of output range	Upper limit of output range	Lower limit of output range	Lower limit of output range

* acc. to NAMUR NE 43

DIP Switch S2

Output Signal Start Temperature				Output Signal End Temperature																																		
1	2	3	4	°C	°F	5	6	7	8	9	10	°C	°F	5	6	7	8	9	10	°C	°F	5	6	7	8	9	10	°C	°F									
				0	32							100	212								75	167									210	410					475	887
●				-200	-328	●						0	32	●							80	176	●							220	428	●				500	932	
	●			-175	-283		●					5	41		●						85	185		●						230	446		●			525	997	
●	●			-150	-238	●	●					10	50	●	●						90	194	●	●						240	464	●	●			550	1022	
	●			-125	-193			●				15	59			●					95	203			●					250	482			●		575	1067	
●	●			-100	-148	●		●				20	68	●		●					100	212	●		●					260	500	●		●		600	1112	
	●	●		-90	-130		●	●				25	77		●	●					110	230		●	●					270	518		●	●		625	1157	
●	●	●		-80	-112	●	●	●				30	86	●	●	●					120	248	●	●	●					280	536	●	●	●		650	1202	
	●			-70	-94				●			35	95			●	●				130	266				●				290	554			●	●	675	1247	
●		●		-60	-76	●			●			40	104	●		●	●				140	284	●			●				300	572	●		●		700	1292	
	●			-50	-58		●		●			45	113		●	●	●				150	302		●		●				325	617		●	●	●	725	1337	
●	●			-40	-40	●	●		●			50	122	●	●	●	●				160	320	●	●	●	●				350	662	●	●	●	●	750	1382	
	●	●		-30	-22			●	●			55	131			●	●	●			170	338			●	●				375	707			●	●	●	775	1427
●	●	●		-20	-4	●		●	●			60	140	●		●	●	●			180	356	●		●	●				400	752	●		●	●	800	1472	
	●	●	●	-10	14		●	●	●			65	149		●	●	●	●			190	374		●	●	●				425	797		●	●	●	825	1517	
●	●	●	●	0	32	●	●	●	●			70	158	●	●	●	●	●			200	392	●	●	●	●				450	842	●	●	●	●	850	1562	

The measurement span must have the following min. magnitude:

- in the Celsius scale (°C): 50 K
- in the Fahrenheit scale (°F): 90 K

Temperature Signal Conditioner; Configurable; for RTD and TC Sensors; Analog 2857 Series

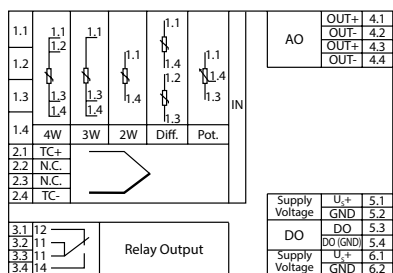

RTD/TC Temperature Signal Conditioner; analog

Item No.	Pack. Unit
2857-535	1

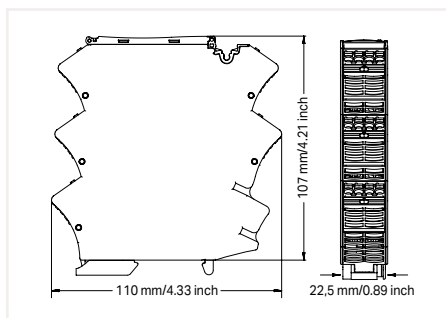

Short description:

WAGO's RTD TC temperature signal conditioner for RTD sensors, potentiometers, resistors and thermocouples monitors and reports signals of up to two switching thresholds. The sensor and status information that is collected is also converted to a standard analog signal.

Features:

- A relay with changeover contact reacts to configured measurement range limits (on/off switching delay and threshold value switch function can be configured with up to two threshold values)
- Configurable Pt factor
- Adjustable software filter
- Simulation of input/output response via interface configuration display
- Input of customer-specific sensors via interface configuration software
- Safe 3-way isolation with 3 kV test voltage per EN 61010-1
- Analog unipolar/bipolar signals (current/voltage) at output
- Additional digital signal output for configured measurement range limits
- Adjustable transfer characteristic

Configuration

Configuration options Interface configuration software; configuration display

Input

Input signal type RTD sensors; Potentiometers; Resistors; TC sensors

Input – RTD Sensors

Sensor types (RTD) Pt10 ... Pt2000 (expandable)
 Sensor connection 2-wire; 3-wire; 4-wire; differential; potentiometer
 Sensor power supply (RTD) max. ≤ 0.5 mA
 Temperature measurement range (RTD) -200 ... +850 °C
 Measurement span (RTD) min. 50 K

Input – TC Sensors

Sensor types (TC) Type J, K, E, R, N, S, T, B, C
 Temperature measurement range (TC) -210 ... +1200 °C (Type J); -200 ... +1372 °C (Type K); -200 ... +1000 °C (Type E); 250 ... 1768 °C (Type R); -200 ... +1300 °C (Type N); -50 ... +1664 °C (Type S); -200 ... +400 °C (Type T); 250 ... 1820 °C (Type B); 0 ... 2320 °C (Type C)
 Measurement min. (TC) 100 K
 Cold junction compensation ON/OFF (default: ON)
 Cold junction error 3 K (2 K typ.)

Input – Resistors

Input range (resistor) 0 ... 10 kΩ
 Input range (potentiometer) 0 ... 10 kΩ
 Measurement span (min.) 50 Ω

Output

Output signal type Current; Voltage
 Output signal (voltage) ±12 V
 Output signal (current) ±24 mA
 Load impedance (voltage output) ≥ 2 kΩ
 Load impedance (current output) ≤ 600 Ω

Output – Digital

Max. switching voltage (DO) Supply voltage applied: -0.3 V
 Max. continuous current (DO) 100 mA (no internal restriction)
 Number of switching thresholds (DO) 1 or 2 (adjustable)
 Configurable rise/fall delay time (DO) 0 ... 60 s (via software)

Output – Relay

Number of changeover/switchover contacts 1
 Switching voltage (max.) 250 VAC
 Limiting continuous current (relay; module assembly) 6 A (≤ 60 °C); 3 A (60 ... +70 °C)
 Dielectric strength, open contact (AC, 1 min) 1 kV_{rms}
 Number of switching thresholds (relay) 1 or 2 (adjustable)
 Configurable rise/fall delay time (relay) 0 ... 60 s (via software)

Signal Processing

Software filter (adjustable) Moving average value (filter level: 30)
 Step response (typ.) 130 ms (2-wire); 700 ms (3-wire); 700 ms (4-wire); 600 ms (differential); 500 ms (potentiometer); 150 ms (cold junction compensation OFF); 400 ms (cold junction compensation ON)

Measurement Error

Transmission error (typ.) ≤ 0.1 % at full measurement span
 Transmission error for the set measurement range ≤ (100 K/set measurement range [K]) %
 Temperature coefficient ≤ 0.01 %/K

Power Supply

Power supply type 24 VDC
 Nominal supply voltage U_s 24 VDC
 Supply voltage range -60 ... +30 %
 Power consumption at nominal supply voltage ≤ 70 mA (+ IDO)

» Configuration software	Page 332
» Configuration display	Page 333
» Accessories	Page 344

Specialty Functions:



Configuration via:

**Safety and Protection**

Rated voltage of the measurement circuit connections per EN 61010-2-030	AC 300 V
Measurement category per EN/UL 61010-2-030	CAT II (input)
Overvoltage category	II
Note on insulation parameters	The digital output (DO) is at the potential of the supply The service interface is at the potential of the analog output The DIN-rail contact (functional ground) is capacitively coupled to the analog output.
Protection type	IP20

Test voltage

Test voltage (input/output/supply)	AC 3 kV; 50 Hz; 1 min
Test voltage (input/analog output/relay output/supply)	3 kVAC; 50 ... 60 Hz; 1 min
Test voltage (input/DIN-rail contact/relay output/supply)	3 kVAC; 50 ... 60 Hz; 1 min

Insulation parameters per EN/UL 61010-1

Line-to-neutral conductor voltage (AC) max.	300 V
Overvoltage category	II
Pollution degree	2
Insulation type (input/analog output/relay output/supply)	Reinforced insulation
Insulation type (input/DIN-rail contact/relay output/supply)	Reinforced insulation

Connection Data

Connection technology	Push-in CAGE CLAMP®
WAGO Connector	<i>picoMAX</i> ® 5.0
Solid conductor	0.2 ... 2.5 mm ² / 24 ... 12 AWG
Fine-stranded conductor	0.2 ... 2.5 mm ² / 24 ... 12 AWG
Strip length	9 ... 10 mm / 0.35 ... 0.39 inch

Geometric Data

Width	22.5 mm / 0.886 inch
Height from upper-edge of DIN-rail	107 mm / 4.213 inch
Depth	110 mm / 4.331 inch

Mechanical Data

Mounting type	DIN-35 rail
---------------	-------------

Material Data

Weight	126.9 g
--------	---------

Environmental Requirements

Surrounding air temperature (operation)	-40 ... +70 °C
Surrounding air temperature (storage)	-40 ... +85 °C
Temperature range of the connecting cable according to EN 61010-2-201	≥ (T _{surrounding air} + 10 K)
Temperature range of connecting cable per UL 61010-2-201 (min.)	90 °C
Relative humidity	5 ... 95 % (non-condensing)
Operating altitude (max.)	2000 m

Standards and Specifications

Conformity marking	CE
EMC immunity to interference	EN 61000-6-2; EN 61326-2-3
EMC emission of interference	EN 61000-6-3; EN 61326-2-3
Standards/specifications	EN 61010-1; EN 61373

Temperature Signal Conditioner; Configurable; for RTD and TC Sensors; Serial 2857 Series

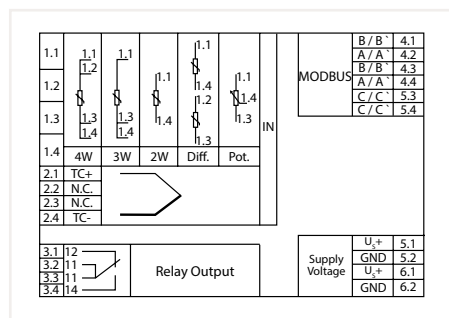

RTD/TC Temperature Signal Conditioner; serial

Item No.	Pack. Unit
2857-535/000-001	1

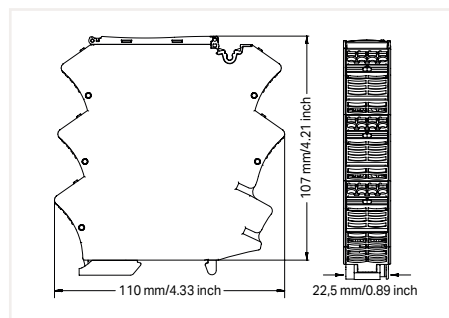

Short description:

WAGO's RTD TC temperature signal conditioner for RTD sensors, potentiometers, resistors and thermocouples monitors and reports signals of up to two switching thresholds. The sensor and status information that is collected is also made available to a higher-order device (e.g., a PLC) via a bus connection.

Features:

- A relay with changeover contact reacts to configured measurement range limits (on/off switching delay and threshold value switch function can be configured with up to two threshold values)
- Configurable Pt factor
- Adjustable software filter
- Simulation of input/output response via interface configuration display
- Input of customer-specific sensors via the interface configuration software
- Safe 3-way isolation with 3 kV test voltage per EN 61010-1
- RS-485 interface with Modbus protocol at the output
- Terminating resistor can be adjusted at the output
- Adjustable transfer characteristic

Configuration

Configuration options	Interface configuration software; Configuration display; Rotary encoder switch
-----------------------	--

Input

Input signal type	RTD sensors; Potentiometers; Resistors; TC sensors
-------------------	--

Input – RTD Sensors

Sensor types (RTD)	Pt10 ... Pt2000 (expandable)
Sensor connection	2-wire; 3-wire; 4-wire; differential; potentiometer
Sensor power supply (RTD) max.	≤ 0.5 mA
Temperature measurement range (RTD)	-200 ... +850 °C
Measurement span (RTD) min.	50 K

Input – TC Sensors

Sensor types (TC)	Type J, K, E, R, N, S, T, B, C
Temperature measurement range (TC)	-210 ... +1200 °C (Type J); -200 ... +1372 °C (Type K); -200 ... +1000 °C (Type E); 250 ... 1768 °C (Type R); -200 ... +1300 °C (Type N); -50 ... +1664 °C (Type S); -200 ... +400 °C (Type T); 250 ... 1820 °C (Type B); 0 ... 3230 °C (Type C)
Measurement min. (TC)	100 K
Cold junction compensation	ON/OFF (default: ON)
Cold junction error	3 K (2 K typ.)

Input – Resistors

Input range (resistor)	0 ... 10 kΩ
Input range (potentiometer)	0 ... 10 kΩ
Measurement span (min.)	50 Ω

Output – Relay

Number of changeover/switchover contacts	1
Switching voltage (max.)	250 VAC
Limiting continuous current (relay; module assembly)	6 A (≤ 60 °C); 3 A (60 ... +70 °C)
Dielectric strength, open contact (AC, 1 min)	1 kV _{rms}
Number of switching thresholds (relay)	1 or 2 (adjustable)
Configurable rise/fall delay time (relay)	0 ... 60 s (via software)

Communication

Communication	Modbus RTU
Interface	RS-485 (2-wire)
Number of participants (max.)	64

Signal Processing

Software filter (adjustable)	Moving average value (filter level: 30)
Step response (typ.)	130 ms (2-wire); 700 ms (3-wire); 700 ms (4-wire); 600 ms (differential); 500 ms (potentiometer); 150 ms (cold junction compensation OFF); 400 ms (cold junction compensation ON)

Measurement Error

Transmission error (typ.)	≤ 0.1 % at full measurement span
Transmission error for the set measurement range	≤ (100 K/set measurement range [K]) %
Temperature coefficient	≤ 0.01 %/K

Power Supply

Power supply type	24 VDC
Nominal supply voltage U _s	24 VDC
Supply voltage range	-60 ... +30 %
Power consumption at nominal supply voltage	≤ 50 mA

» Configuration software	Page 332
» Configuration display	Page 333
» Accessories	Page 344

Specialty Functions:



Configuration via:



Safety and Protection	
Rated voltage of the measurement circuit connections per EN 61010-2-030	AC 300 V
Measurement category per EN/UL 61010-2-030	CAT II (input)
Overvoltage category	II
Note on insulation parameters	The service interface is at the potential of the analog output The DIN-rail contact (functional ground) is capacitively coupled to the analog output.
Protection type	IP20
Test voltage	
Test voltage (input/output/supply)	AC 3 kV; 50 Hz; 1 min
Test voltage (input/analog output/relay output/supply)	3 kVAC; 50 ... 60 Hz; 1 min
Test voltage (input/DIN-rail contact/relay output/supply)	3 kVAC; 50 ... 60 Hz; 1 min
Insulation parameters per EN/UL 61010-1	
Line-to-neutral conductor voltage (AC) max.	300 V
Overvoltage category	II
Pollution degree	2
Insulation type (input/analog output/relay output/supply)	Reinforced insulation
Insulation type (input/DIN-rail contact/relay output/supply)	Reinforced insulation
Connection Data	
Connection technology	Push-in CAGE CLAMP®
WAGO Connector	picoMAX® 5.0
Solid conductor	0.2 ... 2.5 mm² / 24 ... 12 AWG
Fine-stranded conductor	0.2 ... 2.5 mm² / 24 ... 12 AWG
Strip length	9 ... 10 mm / 0.35 ... 0.39 inch
Geometric Data	
Width	22.5 mm / 0.886 inch
Height from upper-edge of DIN-rail	107 mm / 4.213 inch
Depth	110 mm / 4.331 inch
Mechanical Data	
Mounting type	DIN-35 rail
Material Data	
Weight	127.83 g
Environmental Requirements	
Surrounding air temperature (operation)	-40 ... +70 °C
Surrounding air temperature (storage)	-40 ... +85 °C
Temperature range of the connecting cable according to EN 61010-2-201	≥ (T _{surrounding air} + 10 K)
Temperature range of connecting cable per UL 61010-2-201 (min.)	90 °C
Relative humidity	5 ... 95 % (non-condensing)
Operating altitude (max.)	2000 m
Standards and Specifications	
Conformity marking	CE
EMC immunity to interference	EN 61000-6-2; EN 61326-2-3
EMC emission of interference	EN 61000-6-3; EN 61326-2-3
Standards/specifications	EN 61010-1; EN 61373

Temperature Signal Conditioner; Configurable; for Ni Sensors 857 Series

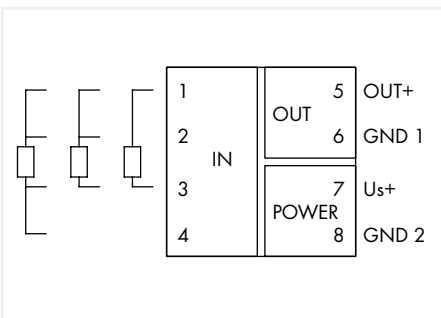
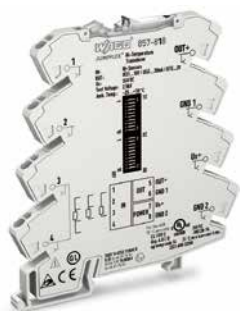

Temperature Signal Conditioner for Ni Sensors; Current and voltage output signal; Supply voltage: 24 VDC; Module width: 6 mm

Item No.	Pack. Unit
857-818	1

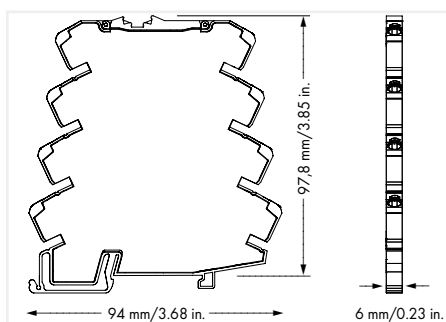

Short description:

WAGO's Ni temperature signal conditioner (Ni = nickel) records signals from Ni sensors featuring all standard characteristics and converts the temperature signal into a standard analog signal at the output.

Features:

- For Ni100, Ni120, Ni200; Ni500 und Ni1000 sensors
- Calibrated measurement range switching
- Switchable clipping
- Limitation of standard analog signal to upper range values
- Safe 3-way isolation with 2.5 kV test voltage per EN 61140

Specialty Functions:



Configuration via:



Configuration	
Configuration options	DIP switch
Input	
Input signal type	Ni sensors
Input voltage (max.)	±31.2 VDC
Input – RTD Sensors	
Sensor types (RTD)	Ni100; Ni120; Ni200; Ni500; Ni1000
Sensor connection	2-wire, 3-wire, 4-wire (switchable)
Output	
Output signal type	Current; Voltage
Output signal (voltage)	0 ... 5 V; 1 ... 5 V; 0 ... 10 V; 2 ... 10 V
Output signal (current)	0 ... 10 mA; 2 ... 10 mA; 0 ... 20 mA; 4 ... 20 mA
Load impedance (voltage output)	≥ 2 kΩ
Load impedance (current output)	≤ 600 Ω
Signal Processing	
Step response (typ.)	60 ms (2-wire); 120 ms (3-wire); 30 ms (4-wire)
Measurement Error	
Transmission error (typ.)	≤ 0.1 % of upper-range value
Power Supply	
Power supply type	24 VDC
Nominal supply voltage U_s	24 VDC
Supply voltage range	±30 %
Power consumption at nominal supply voltage	≤ 40 mA
Safety and Protection	
Test voltage (input/output/supply)	2.5 kVAC; 50 Hz; 1 min
Protection type	IP20
Connection Data	
Connection technology	Push-in CAGE CLAMP®
Solid conductor	0.08 ... 2.5 mm ² / 28 ... 14 AWG
Fine-stranded conductor	0.34 ... 2.5 mm ² / 22 ... 14 AWG
Strip length	9 ... 10 mm / 0.35 ... 0.39 inch
Geometric Data	
Width	6 mm / 0.236 inch
Height from upper-edge of DIN-rail	97.8 mm / 3.85 inch
Depth	94 mm / 3.701 inch
Mechanical Data	
Mounting type	DIN-35 rail
Material Data	
Weight	34.9 g
Environmental Requirements	
Surrounding air temperature (operation)	-25 ... +70 °C
Surrounding air temperature (storage)	-40 ... +85 °C
Relative humidity	5 ... 95 % (non-condensing)
Operating altitude (max.)	2000 m
Standards and Specifications	
Conformity marking	CE
EMC immunity to interference	EN 61000-6-2
EMC emission of interference	EN 61000-6-4

857-818

DIP Switch Adjustability

● = ON Default

DIP Switch S1

Connection Technology		Temperature Coefficient		Sensor Type		
1	2	3	4	5	6	7
	2-wire			6178 ppm/K *1		Ni100
●	3-wire	●		5000 ppm/K	●	Ni120
	4-wire		●	6720 ppm/K		● Ni200
		●	●	6370 ppm/K	●	● Ni500
					●	Ni1000

*1 6178 ppm/K acc. to DIN 4376

DIP Switch S1 DIP Switch S2

Start Temperature			End Temperature																			
8	9	10	°C	1	2	3	4	5	T / °C	1	2	3	4	5	T / °C	1	2	3	4	5	T / °C	
			0						100	●	●		●		100		●	●		●		210
●			-60	●					0			●	●		110	●	●	●		●		220
	●		-50		●				10	●		●	●		120				●	●		230
●	●		-40	●	●				20		●	●	●		130	●			●	●		240
		●	-30			●			30	●	●	●	●		140				●	●		250
●	●		-20	●	●				40					●	150	●	●		●	●		260
	●	●	-10		●	●			50	●				●	160				●	●		270
●	●	●	0	●	●	●			60		●			●	170	●			●	●		280
							●		70	●	●			●	180		●	●	●	●		290
				●			●		80			●		●	190	●	●	●	●	●		300
					●	●			90	●	●			●	200							

DIP Switch S2

Output Signal			9	10	Measurement Range Underflow	Measurement Range Overflow	Wire Break	Short Circuit
6	7	8						
		0 ... 20 mA			Lower limit of output range -5 % **2	Upper limit of output range +2.5 %*2	Upper limit of output range +5 %*2	Lower limit of output range -12.5 % **2
●		4 ... 20 mA						
	●	0 ... 10 mA			Lower limit of output range	Upper limit of output range +2.5 %	Upper limit of output range +5 %	Lower limit of output range
●	●	2 ... 10 mA		●				
		0 ... 10 V			Lower limit of output range	Upper limit of output range	Upper limit of output range +5 %	Upper limit of output range +5 %
●	●	2 ... 10 V		●				
		0 ... 5 V			Lower limit of output range	Upper limit of output range	Lower limit of output range	Lower limit of output range
●	●	1 ... 5 V		●				

* but not when lower limit of output range = 0 V or 0 mA
**2 acc. to NAMUR NE 43

KTY Signal Conditioner; Configurable 857 Series

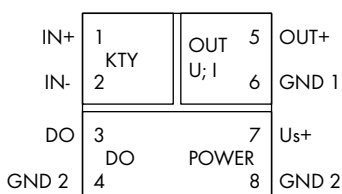
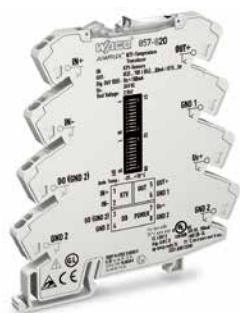

Temperature Signal Conditioner for KTY Sensors; Current and voltage output signal; Supply voltage: 24 VDC; Module width: 6 mm

Item No.	Pack. Unit
857-820	1

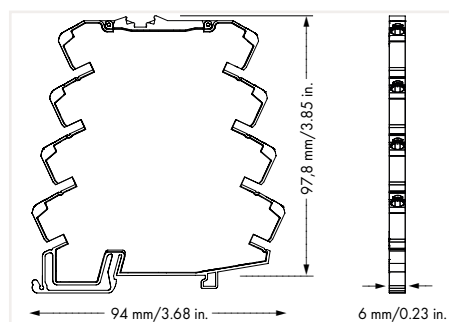

Short description:

WAGO's KTY temperature signal conditioner records signals from KTY sensors featuring all standard characteristics and converts the temperature signal into a standard analog signal at the output.

Features:

- Supports all standard KTY sensors
- Calibrated measurement range switching
- Switchable clipping
- Limitation of standard analog signal to upper range values
- Safe 3-way isolation with 2.5 kV test voltage per EN 61140

Specialty Functions:



Configuration via:



Configuration	
Configuration options	DIP switch
Input	
Input signal type	KTY sensors
Input voltage (max.)	±30 VDC
Input – KTY Sensors	
Sensor types (KTY)	KTY81-110; KTY81-120; KTY81-121; KTY81-122; KTY81-150; KTY81-210; KTY81-220; KTY81-221; KTY81-222; KTY81-250; KTY82-110; KTY82-120; KTY82-121; KTY82-122; KTY82-150; KTY82-220; KTY82-221; KTY82-222; KTY82-250; KTY83-110; KTY83-120; KTY83-121; KTY83-122; KTY83-150; KTY83-151; KTY84-130; KTY84-150; KTY84-151; KTY16; KTY19; ST13; ST20
Sensor connection	2-wire
Output	
Output signal type	Current; Voltage
Output signal (voltage)	0 ... 5 V; 1 ... 5 V; 0 ... 10 V; 2 ... 10 V
Output signal (current)	0 ... 10 mA; 2 ... 10 mA; 0 ... 20 mA; 4 ... 20 mA
Load impedance (voltage output)	≥ 2 kΩ
Load impedance (current output)	≤ 600 Ω
Output – Digital	
Max. switching voltage (DO)	Supply voltage applied
Max. continuous current (DO)	100 mA (no internal restriction)
Signal Processing	
Step response (typ.)	50 ms
Measurement Error	
Transmission error (typ.)	≤ 0.1 % of upper-range value
Power Supply	
Power supply type	24 VDC
Nominal supply voltage U _s	24 VDC
Supply voltage range	±30 %
Power consumption at nominal supply voltage	≤ 40 mA
Safety and Protection	
Test voltage (input/output/supply)	2.5 kVAC; 50 Hz; 1 min
Protection type	IP20
Connection Data	
Connection technology	Push-in CAGE CLAMP®
Solid conductor	0.08 ... 2.5 mm ² / 28 ... 14 AWG
Fine-stranded conductor	0.34 ... 2.5 mm ² / 22 ... 14 AWG
Strip length	9 ... 10 mm / 0.35 ... 0.39 inch
Geometric Data	
Width	6 mm / 0.236 inch
Height from upper-edge of DIN-rail	97.8 mm / 3.85 inch
Depth	94 mm / 3.701 inch
Mechanical Data	
Mounting type	DIN-35 rail
Material Data	
Weight	35.5 g
Environmental Requirements	
Surrounding air temperature (operation)	-25 ... +70 °C
Surrounding air temperature (storage)	-40 ... +85 °C
Relative humidity	5 ... 95 % (non-condensing)
Operating altitude (max.)	2000 m
Standards and Specifications	
Conformity marking	CE
EMC immunity to interference	EN 61000-6-2
EMC emission of interference	EN 61000-6-4

Potentiometer Signal Conditioner; Configurable 857 Series

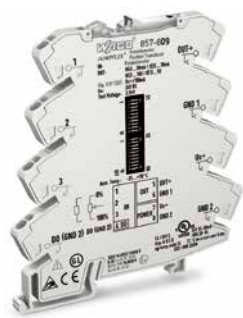

3

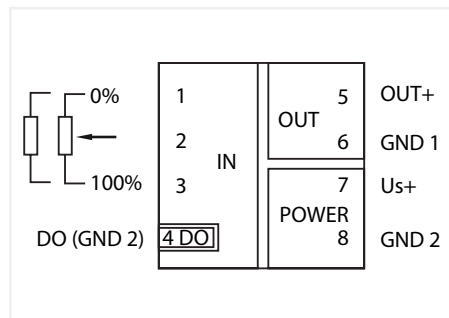

Potentiometer Position Signal Conditioner; Current and voltage output signal; Digital output; Supply voltage: 24 VDC; Module width: 6 mm

Item No.	Pack. Unit
857-809	1

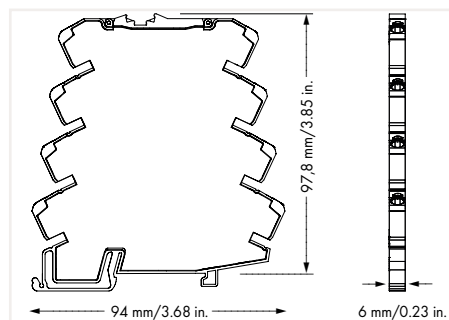

Short description:

WAGO's potentiometer signal conditioner records resistance signals (e.g., from potentiometers) and converts them into a standard analog signal. The device is supplied with 24 VDC (nominal voltage). It is set via DIP switch or push/slide switch.

Features:

- PC configuration interface
- Calibrated measurement range switching
- Automatic potentiometer identification
- Safe 3-way isolation with 2.5 kV test voltage per EN 61140

Note:

Additional setting options via interface configuration software/app

Configuration

Configuration options: DIP switch; Interface configuration software; Interface configuration app; Push/slide switch

Input

Input signal type: Potentiometer; Resistor

Input – Resistors

Input range (resistor): 10 Ω ... 100 kΩ
 Input range (potentiometer): 100 Ω ... 100 kΩ
 Potentiometer supply voltage (max.): 2.5 V
 Measurement range (min.): 100 Ω

Output

Output signal type: Current; Voltage
 Output signal (voltage): 0 ... 5 V; 1 ... 5 V; 0 ... 10 V; 2 ... 10 V
 Output signal (current): 0 ... 10 mA; 2 ... 10 mA; 0 ... 20 mA; 4 ... 20 mA
 Load impedance (voltage output): ≥ 2 kΩ
 Load impedance (current output): ≤ 600 Ω

Output – Digital

Max. switching voltage (DO): Supply voltage applied
 Max. continuous current (DO): 100 mA (no internal restriction)
 Number of switching thresholds (DO): 1 (adjustable)

Signal Processing

Step response (typ.): 32 ms

Measurement Error

Transmission error (typ.): ≤ 0.1 % of upper-range value
 Temperature coefficient: ≤ 0.01 %/K

Power Supply

Power supply type: 24 VDC
 Nominal supply voltage U_s : 24 VDC
 Supply voltage range: ±30 %
 Power consumption at nominal supply voltage: ≤ 40 mA (+ IDO)

Safety and Protection

Test voltage (input/output/supply): 2.5 kVAC; 50 Hz; 1 min
 Protection type: IP20

Connection Data

Connection technology: Push-in CAGE CLAMP®
 Solid conductor: 0.08 ... 2.5 mm² / 28 ... 14 AWG
 Fine-stranded conductor: 0.34 ... 2.5 mm² / 22 ... 14 AWG
 Strip length: 9 ... 10 mm / 0.35 ... 0.39 inch

Geometric Data

Width: 6 mm / 0.236 inch
 Height from upper-edge of DIN-rail: 97.8 mm / 3.85 inch
 Depth: 94 mm / 3.701 inch

Mechanical Data

Mounting type: DIN-35 rail

Material Data

Weight: 36.6 g

Environmental Requirements

Surrounding air temperature (operation): -25 ... +70 °C
 Surrounding air temperature (storage): -40 ... +85 °C
 Relative humidity: 5 ... 95 % (non-condensing)
 Operating altitude (max.): 2000 m

Standards and Specifications

Conformity marking: CE
 EMC immunity to interference: EN 61000-6-2
 EMC emission of interference: EN 61000-6-4

» Configuration software	Page 332
» Configuration App	Page 333
» Accessories	Page 344

Specialty Functions:



Configuration via:



857-809

DIP Switch Adjustability

• = ON Default

DIP Switch S1 und S2

Input		Start Value					End Value						
DIP S1		DIP S1					Resistor Ω			DIP S1		DIP S2	Resistor Ω
1		2	3	4	5	6	7	8	9	10	1		
•	Potentiometer						0					100000	
	Resistor	•					0	•				0	
			•				10		•			10	
		•	•				11	•	•			11	
				•			12			•		12	
		•		•			13	•		•		13	
			•	•			15		•	•		15	
		•	•	•			16	•	•	•		16	
					•		18				•	18	
		•			•		20	•			•	20	
			•		•		22		•		•	22	
		•	•		•		24	•	•		•	24	
				•	•		27			•	•	27	
		•		•	•		30	•		•	•	30	
			•	•	•		33		•	•	•	33	
		•	•	•	•		36	•	•	•	•	36	
						•	39				•	39	
		•			•		43	•			•	43	
			•		•		47		•		•	47	
		•	•		•		51	•	•		•	51	
				•	•		56			•	•	56	
		•		•	•		62	•		•	•	62	
			•	•	•		68		•	•	•	68	
		•	•	•	•		75	•	•	•	•	75	
					•	•	82				•	•	82
		•			•	•	91	•			•	•	91
			•		•	•	40		•		•	•	40
		•	•		•	•	50	•	•		•	•	50
				•	•	•	60			•	•	•	60
		•		•	•	•	70	•		•	•	•	70
			•	•	•	•	80		•	•	•	•	80
		•	•	•	•	•	90	•	•	•	•	•	90

DIP Switch S2

Factor of Initial Value			Factor of End Value			Output		Output Signal Range			
2	3		4	5		6		7	8		
		x1			x1		Current			0 ... 10 V/0 ... 20 mA	
•		x10	•		x10	•	Voltage	•		2 ... 10 V/4 ... 20 mA	
	•	x100		•	x100				•	0 ... 5 V/0 ... 10 mA	
•	•	x1000	•	•	x1000			•	•	1 ... 5 V/2 ... 10 mA	
9		10	Measurement Range Underflow			Measurement Range Overflow			Wire Break		
			Upper limit of output range* +2.5 %			Lower limit of output range* -5 %			Upper limit of output range* +5 %		
•			Upper limit of output range +2.5 %			Lower limit of output range			Upper limit of output range +5 %		
	•		Upper limit of output range			Lower limit of output range			Upper limit of output range +5 %		
•	•		Upper limit of output range			Lower limit of output range			Lower limit of output range		

* acc. to NAMUR NE 45

Frequency Signal Conditioner; Configurable 857 Series

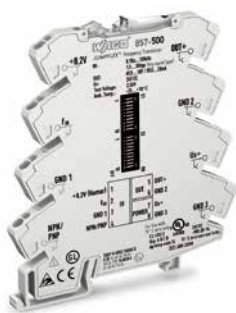

3

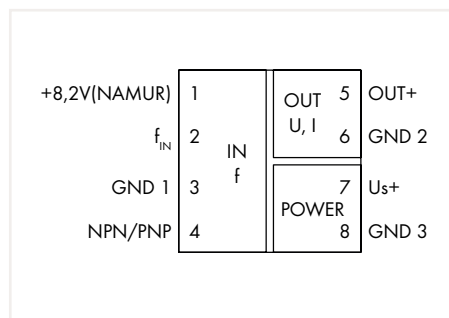

Frequency Signal Conditioner; Current and voltage output signals; Supply voltage: 24 VDC; Module width: 6 mm

Item No.	Pack. Unit
857-500	1

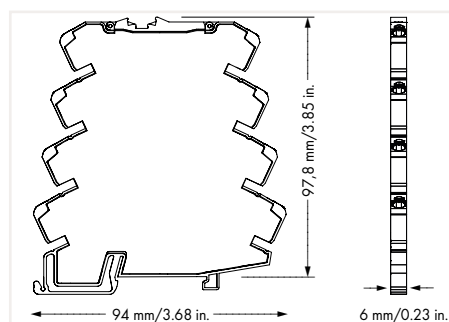

Short description:

WAGO's frequency signal conditioner collects 0.1–120 kHz signals from NAMUR, NPN or PNP sensors and converts them into a standard analog signal.

Features:

- PC configuration interface
- Signal acquisition from NAMUR, NPN or PNP sensors
- Calibrated measurement range switching
- Safe 3-way isolation with 2.5 kV test voltage per EN 61140

Specialty Functions:



Configuration via:



» Configuration software	Page 332
» Configuration App	Page 333
» Accessories	Page 344

Configuration

Configuration options	DIP switch; Interface configuration software; Interface configuration app
-----------------------	---

Input

Input signal type	Frequency generators; NAMUR sensors; NPN/PNP transistor outputs; Mechanical contact (dry contact)
-------------------	---

Input – Sensor Type 1

Sensor type 1	Frequency generator; NPN/PNP transistor output with pull-up or pull-down resistor
Measurement range (frequency) 1	0.1 Hz ... 120 kHz
Pulse length 1	≥ 1 μs
Measurement span 1 (min.)	10 Hz
Signal level	1.5 V; 10 V; 20 V (switchable)
Input voltage (max.)	±31.2 VDC
Signal form	Any
Coupling	AC/DC (adjustable; AC above 10 Hz)
Input resistance 1	10 kΩ

Input – Sensor Type 2

Sensor type 2	NAMUR sensor per DIN EN 50227
Measurement range (frequency) 2	0.1 Hz ... 1 kHz
Pulse length 2	≥ 500 μs
Measurement span 2 (min.)	10 Hz
Sensor supply	8.2 VDC
Signal current (0)	≤ 1.2 mA
Signal current (1)	≥ 2.1 mA
Hysteresis	0.45 mA
Short circuit monitoring	≥ 4.7 mA
Wire break monitoring	≤ 0.2 mA
Input resistance 2	≤ 600 Ω

Input – Sensor Type 3

Sensor type 3	NPN/PNP transistor output without pull-up or pull-down resistor; Mechanical contact (dry contact)
Measurement range (frequency) 3	0.1 Hz ... 20 kHz
Pulse length 3	≥ 25 μs
Measurement span 3 (min.)	100 Hz
Open-circuit voltage	5 VDC
NPN residual voltage	≤ 1.5 V
PNP switching voltage	≥ 7.5 V (+ residual voltage U _{CE sat})

Output

Output signal type	Current; Voltage
Output signal (voltage)	0 ... 5 V; 1 ... 5 V; 0 ... 10 V; 2 ... 10 V
Output signal (current)	0 ... 10 mA; 2 ... 10 mA; 0 ... 20 mA; 4 ... 20 mA
Load impedance (voltage output)	≥ 2 kΩ
Load impedance (current output)	≤ 600 Ω

Signal Processing

Conversion time	Peak-time measurement method (> 400 Hz): < 20 ms; Pulse time measurement method (< 400 Hz): < 200 μs + T _{Cycle duration}
-----------------	--

Measurement Error

Transmission error (typ.)	≤ 0.1 % of upper-range value
Temperature coefficient	≤ 0.01 %/K

Power Supply

Art der Versorgung	24 VDC
Nominal supply voltage U _s	24 VDC
Supply voltage range	±30 %
Power consumption at nominal supply voltage	≤ 40 mA

Safety and Protection

Test voltage (input/output/supply)	2.5 kVAC; 50 Hz; 1 min
Protection type	IP20

Connection Data

Connection technology	Push-in CAGE CLAMP®
Solid conductor	0.08 ... 2.5 mm ² / 28 ... 14 AWG
Fine-stranded conductor	0.34 ... 2.5 mm ² / 22 ... 14 AWG
Strip length	9 ... 10 mm / 0.35 ... 0.39 inch

Geometric Data	
Width	6 mm / 0.236 inch
Height from upper-edge of DIN-rail	97.8 mm / 3.85 inch
Depth	94 mm / 3.701 inch
Mechanical Data	
Mounting type	DIN-35 rail
Material Data	
Weight	36.2 g
Environmental Requirements	
Surrounding air temperature (operation)	-25 ... +70 °C
Surrounding air temperature (storage)	-40 ... +85 °C
Relative humidity	5 ... 95 % (non-condensing)
Operating altitude (max.)	2000 m
Standards and Specifications	
Conformity marking	CE
EMC immunity to interference	EN 61000-6-2
EMC emission of interference	EN 61000-6-4
Standards/Specifications	EN 61373

Frequency Signal Conditioner; Configurable 857 Series

857-500

DIP Switch Adjustability

● = ON Default

DIP Switch S1

Source Input		Coupling	Operation with Disturbed Frequency Signals for Acceptable Signal Level (applies only to f_{in} input)	
1	2	3	4	5
			High	Low
Frequency generator or NPN/PNP transistor outputs with pull-up or pull-down resistor		AC/DC	> 1.5 V	< 0.4 V
●	NAMUR	● AC (without DC), see Figure 1	> 10 V	< 8 V
●	NPN/PNP transistor outputs without pull-up or pull-down resistor input		> 20 V	< 16 V
●	Dry Contact		> 1.5 V	< 0.4 V

DIP Switch S1

DIP Switch S2

Input Start Value					Frequency/Hz	Input End Value					Frequency/Hz
6	7	8	9	10		1	2	3	4	5	
					100						1000
●					0.1	●					0.1
	●				1		●				1
●	●				100	●	●				100
		●			200			●			200
●		●			300	●	●				300
	●	●			400		●	●			400
●	●	●			500	●	●	●			500
			●		600				●		600
●		●	●		700	●			●		700
	●	●			800		●	●			800
●	●	●			900	●	●	●			900
			●		1000			●	●		1000
●	●	●	●		2000	●	●	●			2000
	●	●	●		3000		●	●	●		3000
●	●	●	●		4000	●	●	●	●		4000
			●		5000					●	5000
●		●	●		6000	●			●		6000
	●		●		7000		●		●		7000
●	●		●		8000	●	●		●		8000
		●	●		9000			●	●		9000
●	●	●	●		10000	●	●	●	●		10000
	●	●	●		20000		●	●	●		20000
●	●	●	●		30000	●	●	●	●		30000
			●	●	40000				●	●	40000
●		●	●	●	50000	●		●	●		50000
	●	●	●	●	60000		●	●	●		60000
●	●	●	●	●	70000	●	●	●	●		70000
		●	●	●	80000			●	●	●	80000
●	●	●	●	●	90000	●	●	●	●		90000
	●	●	●	●	100000		●	●	●	●	100000
●	●	●	●	●	120000	●	●	●	●	●	120000

DIP Switch S2

Output Signal			9	10	Measurement Range Underflow	Measurement Range Overflow	Only for NAMUR Sensors	
6	7	8					Wire Break	Short Circuit
		0 ... 20 mA	●	●	Lower limit of output range* -5 %	Upper limit of output range* +2.5 %	Upper limit of output range* 5 %	Lower limit of output range* -12.5 %
●		4 ... 20 mA					Upper limit of output range 5 %	Lower limit of output range
		0 ... 10 mA	●	●	Lower limit of output range	Upper limit of output range +2.5 %	Upper limit of output range 5 %	Lower limit of output range
●	●	2 ... 10 mA					Upper limit of output range 5 %	Lower limit of output range
		0 ... 10 V	●	●	Lower limit of output range	Upper limit of output range	Upper limit of output range 5 %	Upper limit of output range 5 %
●	●	2 ... 10 V					Upper limit of output range 5 %	Lower limit of output range
		0 ... 5 V	●	●	Lower limit of output range	Upper limit of output range	Ausgangsbereichsanfang	Lower limit of output range
●	●	1 ... 5 V					Ausgangsbereichsanfang	Lower limit of output range

*acc. to NAMUR NE 43

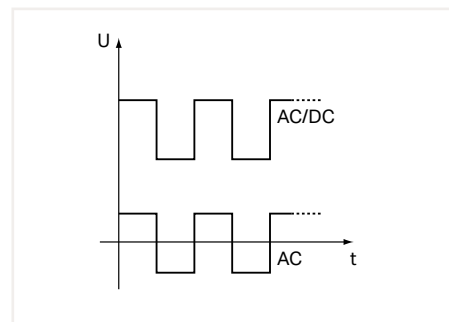

Figure 1: Coupling

3

857-500

Wiring Material

2-Wire DC (Mechanical Contact)

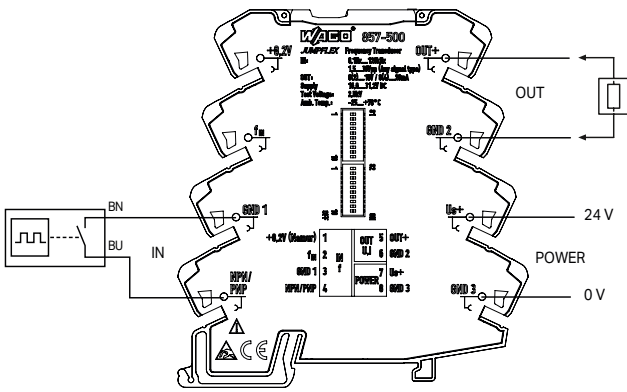

2-Wire DC NAMUR Sensor

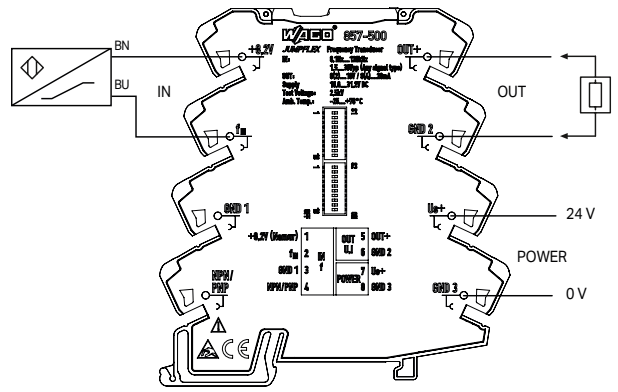

NPN Transistor Output

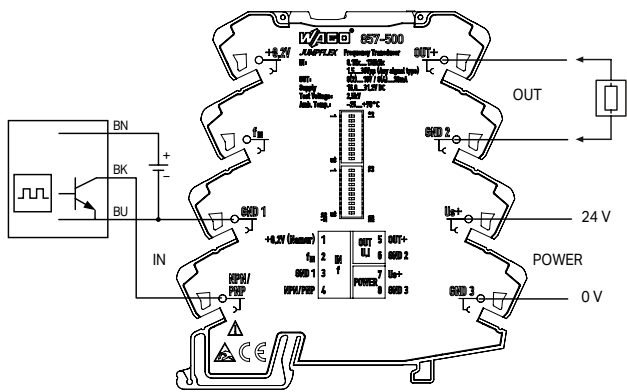

NPN Transistor Output with Pull-Up Resistor

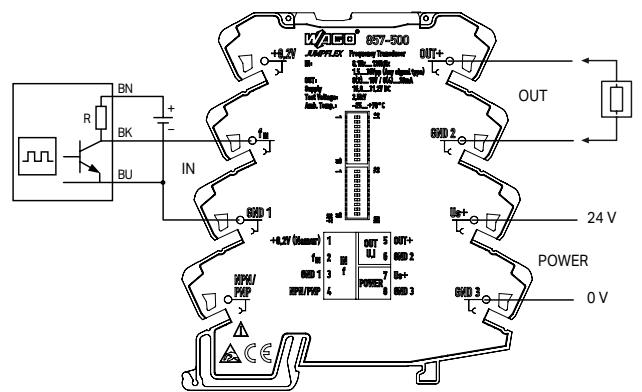

PNP Transistor Output

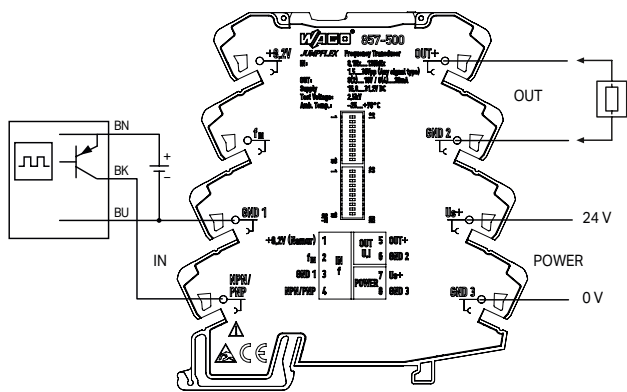

PNP Transistor Output with Pull-Down Resistor

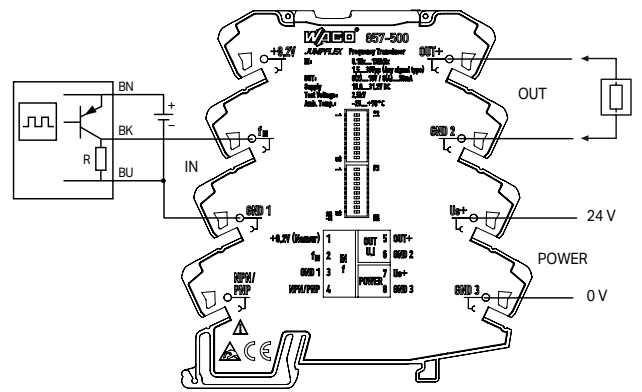

Frequency Generator

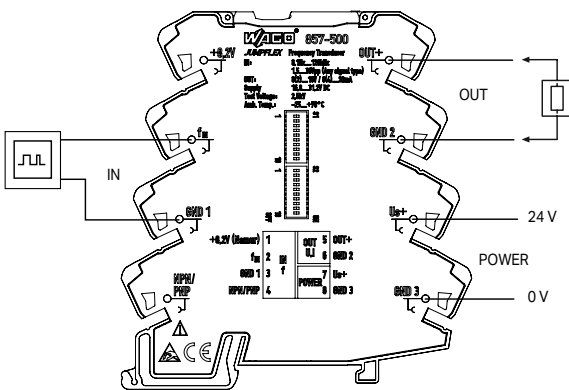

Interface Configuration Software

All signal conditioners offer user-friendly configuration at a glance using the interface configuration software.

All devices marked with the software symbol can be configured accordingly via the software.



Software features:

- Simulation of input and output parameters (2857 Series)
- Automatic module recognition
- Configuration and visualization of process values
- Parameterization of the digital switch output (threshold functionality)
- Communication via WAGO USB Service Cable (750-923) or WAGO Bluetooth® Adapter (750-921), pluggable on both series
- Creation of configuration reports
- Backup of configuration settings

3

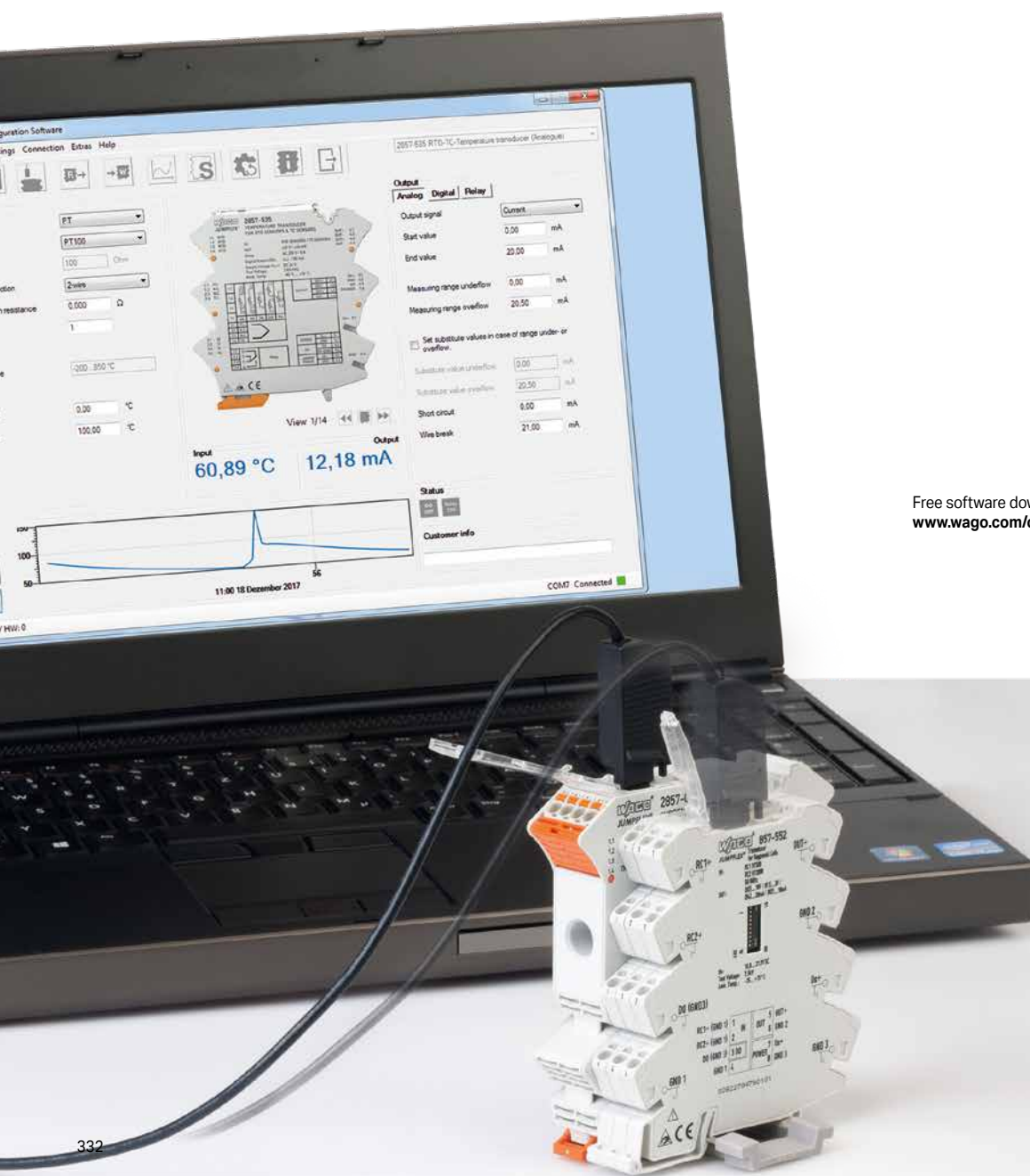

Free software download at:
www.wago.com/configuration-software

JUMPFLEX®-ToGo Configuration App

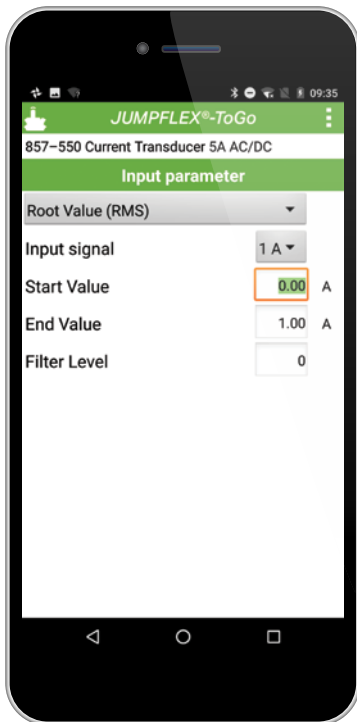

(Android smartphone)

The JUMPFLEX®-ToGo App brings the power of PC-based configuration software to your Android mobile device.

All devices marked with the app symbol can be configured accordingly via the app.



App features:

- Configuration of input and output parameters with a stroke of the finger
- Simple display of configuration data and current value
- Communication via WAGO Bluetooth® Adapter (750-921)

3



Free download from Google Play Store



Bluetooth® Adapter, 750-921

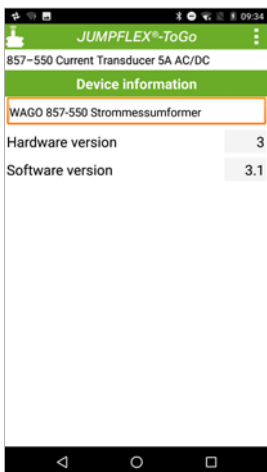

Device information

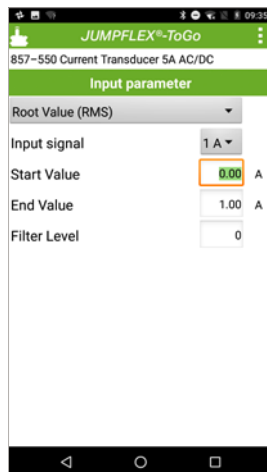

Input parameters

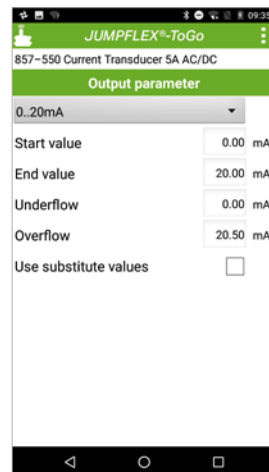

Output parameters

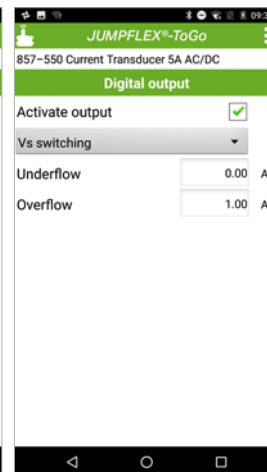

Digital output

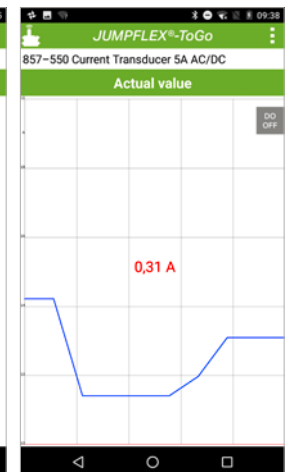

Actual value

Configuration Display 2857 Series



Configuration Display

Item No.	Pack. Unit
2857-900	1

Features:

- Easy mounting on 2857 Series devices
- Automatic module recognition
- Capacitive user interface with slider function
- Intuitive menu navigation
- Multicolor backlight for status indication
- Device configuration and process value visualization
- Easy copying of device configuration

All devices marked with the display symbol  can be configured accordingly via the display.

Operating Data

Operating voltage	3.3 VDC
Power consumption	≤ 60 mA

Geometric Data

Width	22 mm / 0.866 inch
Height	13 mm / 0.512 inch
Depth	59 mm / 2.323 inch

Mechanical Data

Mounting type	Pluggable module
---------------	------------------

Material Data

Weight	24.3 g
--------	--------

Environmental Requirements

Surrounding air temperature (operation)	-20 ... +70 °C
Surrounding air temperature (storage)	-30 ... +80 °C
Relative humidity	10 ... 90 % (non-condensing)
Operating altitude (max.)	2000 m

Standards and Specifications

Conformity marking	CE
EMC immunity to interference	EN 61000-6-2; EN 61326-2-3; EN 50121-3-2
EMC emission of interference	EN 61000-6-4; EN 61326-2-3; EN 50121-3-2
Standards/specifications	EN 61373



Housing width: 22.5 mm

Housing width: 12.5 mm

Bluetooth® Adapter 750 Series



Bluetooth® Adapter		
Item No.	Pack. Unit	
750-921	1	

Bluetooth® Adapter in Connection with 750 Series

The *Bluetooth®* Adapter wirelessly connects a notebook computer with *Bluetooth®* functionality to the service interface of the coupler/controller. It also provides an active connection to a programmable fieldbus controller.

As a cable substitute, the *Bluetooth®* Adapter allows communication between two fieldbus controllers, as well as between fieldbus couplers/controllers via WAGO software tools (e.g., WAGO-I/O-CHECK, WAGO-I/O-PRO).

Configurable coexistence properties ensure trouble-free operation in the presence of other radio systems.

Bluetooth® Adapter in Connection with 857 Series

The *Bluetooth®* Adapter wirelessly connects a notebook computer with *Bluetooth®* functionality to the service interface of a configurable 857 Series Module.

As a cable substitute, the *Bluetooth®* adapter allows communication between modules and the WAGO software tool (WAGOframe) or configuration app for Android-based end-devices.

If required, adapter configuration may be performed via AT commands.

The adapter is supplied via both service interface and power supply of coupler/controller or module.

Technical Data	
Security encryption	128-bit encryption
Radio technology	Bluetooth® 2.1
Frequency band	ISM band, 2402 ... 2483 MHz
Security authentication	Pin code or configurable access list
Supported profiles	Serial Port Profile (SPP)
Type of communication	Peer-to-peer connection
Coexistence	Frequency hopping spread spectrum (FHSS); Adaptive frequency hopping (AFH); Adaptive transmission power with configurable upper limit; Configurable channel blacklist; Supports coexistence optimized inquiry (transmission time ≤ 0.1 s; transmission cycle ≥ 2.9 s)
Transmission range	20 m in open air (Class 2)
Antenna	Integrated
Receiver sensitivity	-82 dBm
Configuration options	AT commands (e.g., via HyperTerminal)
Current consumption (system supply)	60 mA
Indicators	Operating mode

Connection Data	
Contact type	4-pole male connector
Connection type	4-pole male connector

Geometric Data	
Width	15 mm / 0.591 inch
Height	50 mm / 1.969 inch
Depth	19 mm / 0.748 inch

Material Data	
Color	light gray
Weight	16.6 g
Conformity marking	CE

Environmental Requirements	
Surrounding air temperature (operation)	-20 ... +60 °C
Protection type	IP20



Application example: 750 Series



Application example: 857 Series

WAGO USB Communication Cable 750 Series



Configuration Cable; USB connection

Length	Item No.	Pack. Unit
2.5 m	750-923	1
5.0 m	750-923/000-001	1

The WAGO USB Communication Cable connects a PC (notebook) to both the service interface of the 857/2857 Series Signal Conditioners and the configuration interface of WAGO's I/O fieldbus couplers/controllers.

Notice:

Using the WAGO 759-923 USB Communication Cable in combination with select programmable fieldbus controllers requires the specific firmware versions listed below (or higher):

750-841: version 12 and higher

750-872/0020-0000: version 2 and higher

Technical Data

Connection type	4-pole male connector; USB plug (type A)
Number of poles	4
Supported operating systems	Windows XP (SP3 or higher); Windows 7 ; Windows 10

Geometric Data

Width	15 mm / 0.591 inch
Height	50 mm / 1.97 inch
Depth	19 mm / 0.748 inch

Mechanical Data

Weight	64.8 g
Color	black

Environmental Requirements

Surrounding air temperature (operation)	-25 ... +70 °C
Protection type	IP20
EMC immunity to interference	Per EN 61000-4-3, EN 61000-4-6
EMC emission of interference	Per EN 55022

3

Interface Adapter 857 Series

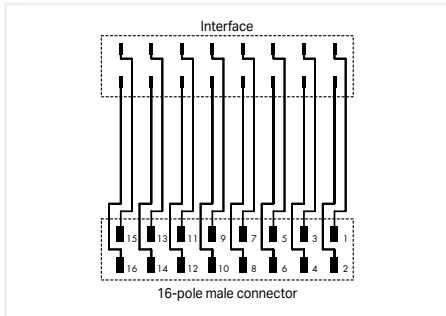
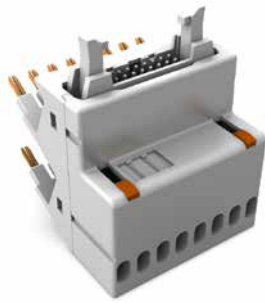

Interface Adapter; with 16-pole ribbon cable connector (DIN 41651); analog

	Item No.	Pack. Unit
	857-980	1

Electrical Data	
Inputs/Outputs	8-channel analog input or output
Circuit type	Analog
Limiting continuous current	1 A
Contact resistance	≤ 20 mΩ
Safety and Protection	
Pollution degree	2
Overvoltage category	III
Test voltage	500 VAC; 50 Hz; 1 min
Connection Data	
Connection type 1	System
Pole number 1	16
Connector 1	DIN 41651 male connector
Performance level 1	3
Connection type 2	Field
Pole number 2	16
Design 2	Plug for jumper slot
Mechanical Data	
Mounting type	Pluggable module
Material Data	
Weight	41.4 g
Environmental Requirements	
Surrounding air temperature (operation)	-20 ... +70 °C
Surrounding air temperature (storage)	-40 ... +85 °C
Relative humidity	5 ... 95 % (no condensation permissible)
Operating altitude (max.)	2000 m

Supply and Through Module 857 Series

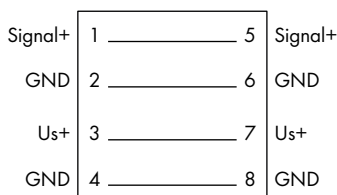

Supply and Through Module

Item No.	Pack. Unit
857-979	25

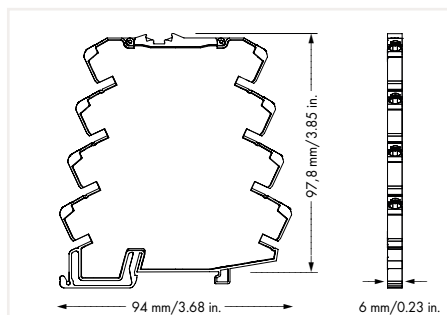

Short description:

WAGO's supply and through module transmits electrically isolated signals, e.g., in conjunction with the 857-980 Interface Adapter for analog signals (Item No. 857-980). When used as a supply module, it transmits the power from the connected clamping points to the adjacent modules via push-in type jumper bars.

Electrical Data

Operating voltage	≤ 33 V AC/DC
Continuous current (max.)	8 A
Contact resistance	≤ 10 Ω

Safety and Protection

Protection type	IP20
-----------------	------

Connection Data

Connection technology	Push-in CAGE CLAMP®
Solid conductor	0.08 ... 2.5 mm ² / 28 ... 14 AWG
Fine-stranded conductor	0.34 ... 2.5 mm ² / 22 ... 14 AWG
Strip length	9 ... 10 mm / 0.35 ... 0.39 inch

Geometric Data

Width	6 mm / 0.236 inch
Height from upper-edge of DIN-rail	97.8 mm / 3.85 inch
Depth	94 mm / 3.701 inch

Mechanical Data

Mounting type	DIN-35 rail
Protection type	IP20

Material Data

Weight	28.8 g
--------	--------

Environmental Requirements

Surrounding air temperature (operation)	-25 ... +70 °C
Surrounding air temperature (storage)	-40 ... +85 °C
Relative humidity	5 ... 95 % (no condensation permissible)
Operating altitude (max.)	2000 m

Standards and Specifications

Conformity marking	CE
--------------------	----

857-979**Application example:**

Power supply for 8 modules with plugged interface adapter

- WAGO interface adapter, 857-980
- WAGO ribbon cable, 706-100/1602-200, 16-pole socket/open-ended
- Push-in type jumper bar, 9-way, 859-409

1

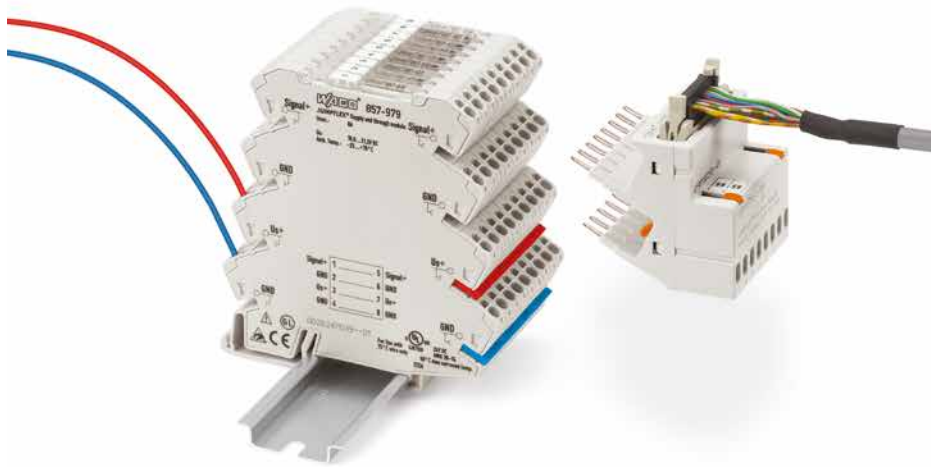

2

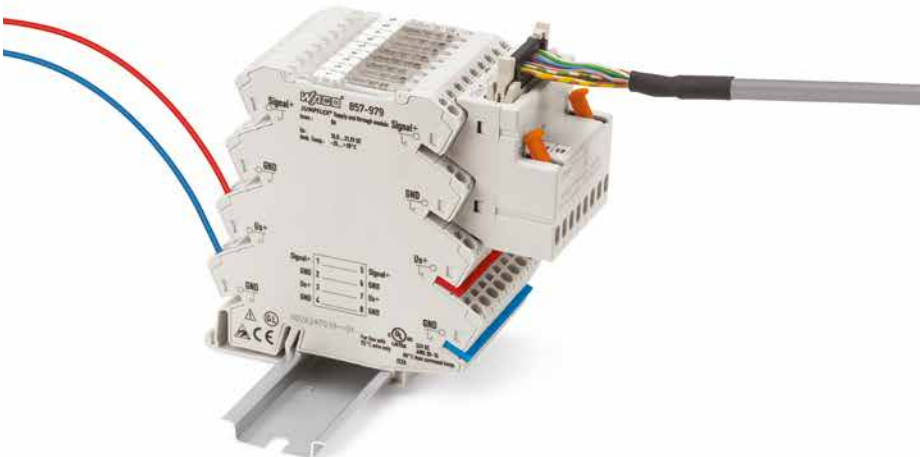

Connection Cable; Paired with an Interface Adapter

706 Series



3

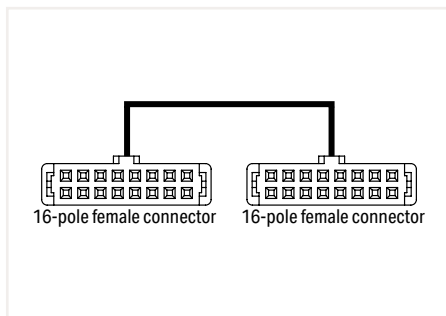

Connection Cable; 16-pole;
DIN 41651 connector; 16-pole; DIN 41651 connector;
Conductor cross section: 0.14 mm²/24 AWG

Length	Item No.	Pack. Unit
1 m	706-753/301-100	1
2 m	706-753/301-200	1
3 m	706-753/301-300	1

WAGO's 16-pole connection cables transmit the signal one-to-one from the 16-pole connector and are available in 1-, 2- and 3-meter lengths. Signal transmission from the 857-980 Interface Adapter is also possible.

They are suitable for system wiring when paired with WAGO's Interface Adapter (Item No. 857-980).

Note:

When using more than 10 wires, the maximum current per wire must be reduced to 0.7 A.

Electrical Data

Operating voltage	≤ 35 VDC
Current per wire (max.)	1 A

Safety and Protection

Degree of protection	IP20
----------------------	------

Connection Data

Connection type 1	System
Pole number 1	16
Pluggable connectors	Pluggable connector per DIN 41651; Female connector
Connection type 2	System
Pole number 2	16
Connector 2	Pluggable connector per DIN 41651; Female connector
Cable type	LiYY
Wire cross-section	0.14 mm ²
Color code	per DIN VDE 47100

Environmental Requirements

Surrounding air temperature (operation)	-25 ... +70 °C
---	----------------

Connection Cable; Paired with an Interface Adapter 706 Series



Connection Cable; 16-pole;
DIN 41651 connector; open-ended; Conductor cross
section: 0.14 mm²/24 AWG; UR components

Length	Item No.	Pack. Unit
2 m	706-100/1602-200	1

Color Coding		HE 10 16-pole
acc. to DIN VDE 47100		Contact Number
white		1
brown		2
green		3
yellow		4
gray		5
pink		6
blue		7
red		8
black		9
violet		10
gray/pink		11
red/blue		12
white/green		13
brown/green		14
white/yellow		15
yellow/brown		16

Note:
When using more than 10 wires, the maximum current per
wire must be reduced to 0.7 A.

Electrical Data	
Operating voltage	≤ 35 VDC
Current per wire (max.)	1 A
Safety and Protection	
Degree of protection	IP20
Connection Data	
Connectors	1 x 16-pole connector per DIN 41651; open-ended
Color code	DIN VDE 47100
Wire cross section	0.14 mm ² /24 AWG LiYY
Physical Data	
Cable length	2 m
Material Data	
Weight	202 g
Environmental Requirements	
Surrounding air temperature (operation)	-25 ... +70 °C

Switched-Mode Power Supply in 2857 Series Housing 787 Series

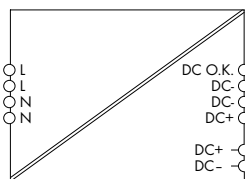

Switched-Mode Power Supply; for signal conditioners;
1-phase; Output voltage: 24 VDC; Output current: 1 A

Item No.	Pack. Unit
787-2852	1

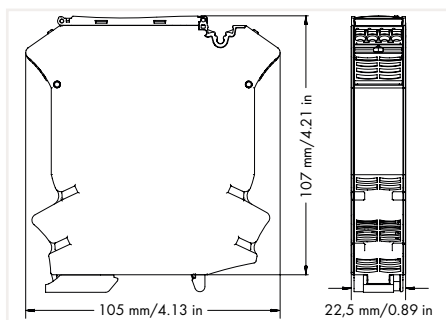

- Switched-mode power supply in 22.5 mm wide 2857 Series housing, same profile as 2857 and 857 Series Signal Conditioners
- Both 24 VDC and 0 V output voltage can be easily supplied to adjacent modules via 859-4xx Jumpers
- Pluggable *picoMAX*® connection technology
- Natural convection cooling
- DC OK message as active signal output (24 VDC; 20 mA)
- Integrated redundancy diode enables easy fail-safe power supply via parallel connection of two power supplies
- Approvals for worldwide applications with modules (pending)

Input	
Phases	1
Nominal input voltage $U_{i, \text{nom}}$	100 ... 240 VAC
Input voltage range	85 ... 264 VAC; 120 ... 372 VDC
Nominal mains frequency range	47 ... 63 Hz; 0 Hz
Input current I_i	≤ 0.28 A (240 VAC; nominal load); ≤ 0.49 A (100 VAC; nominal load)
Discharge current	≤ 1 mA
Inrush current	≤ 30 A
Power factor	≥ 0.6 (230 VAC, nominal load; per EN 61000-3-2)
Power factor correction (PFC)	None
Mains failure hold-up time	≥ 20 ms (100 VAC)

Output	
Nominal output voltage $U_{o, \text{nom}}$	24 VDC (SELV)
Default setting	24 VDC
Nominal output current $I_{o, \text{nom}}$	1 A
Nominal output power	24 W
Adjustment accuracy	≤ 2 %
Deviation; Dynamic load change: 10 ... 90 %	≤ 1 %
Residual ripple	≤ 100 mV (peak-to-peak)
Current limitation	$1.1 \times I_{o, \text{nom}}$ typ.
Overload behavior	Constant current

Signaling and Communication	
Signaling	1 x DC OK LED (green); 1 x Overload LED (red); 1 x active DC OK signal output (24 VDC; 20 mA)
Status indication	Green LED ($U_o > 21.5$ V); Red LED (overload)

Efficiency/Power Losses	
Power loss P_i	≤ 1 W (230 VAC; no load); ≤ 4.3 W (230 VAC; nominal load)
Power loss (max.) $P_{i, \text{max}}$	≤ 5 W (100 VAC / 24 VDC; 1 A)
Efficiency (typ.)	86 % (230 VAC; nominal load); 84 % (110 VAC, nominal load);

Fuse Protection	
Internal fuse	T 2 A / 250 VAC
Recommended backup fusing	Circuit breaker: 6 A, 10 A, 16 A; Tripping characteristic: B or C

Safety and Protection	
Isolation voltage (pri.-sec.)	4.242 kVDC
Pollution degree	2
Protection class	II
Protection type	IP20 (per EN 60529)
Feedback voltage	≤ 60 VDC
Transient suppression (primary)	Varistor
Overvoltage protection (secondary)	Internal protective circuit; ≤ 29 ... 31 VDC (in the event of a fault)
Short-circuit-protected	Yes
Open-circuit-proof	Yes
Parallel operation	Yes, for two devices of the same type
Series operation	Yes, for two devices of the same type
MTBF	$> 500,000$ h (at $+25$ °C per IEC 61709)

Connection Data	
Number of jumper slots	4
Connection type 1	Input/output/signaling
Connection technology	Push-in CAGE CLAMP®
WAGO Connector	<i>picoMAX</i> ® 5.0
Solid conductor	0.2 ... 2.5 mm ² / 24 ... 10 AWG
Fine-stranded conductor	0.2 ... 2.5 mm ² / 24 ... 10 AWG
Strip length	9 ... 10 mm / 0.35 ... 0.39 inch

Geometric Data	
Width	22.5 mm / 0.89 inch
Height from upper-edge of DIN-rail	107 mm / 4.21 inch
Depth	105 mm / 4.13 inch

Mechanical Data	
Mounting type	DIN-35 rail (EN 60715)
Material Data	
Weight	200 g
Environmental Requirements	
Surrounding air temperature (operation)	-25 ... +70 °C
Surrounding air temperature (storage)	-25 ... +85 °C
Relative humidity	5 ... 96 % (no condensation permissible)
Derating	-2 %/K (> +60 °C)
Climatic category	3K3 (per EN 60721)
Standards and Specifications	
Conformity marking	CE
Standards/specifications	EN 61000-6-2; EN 61000-6-3; EN 60950-1; UL 60950*; cULus 508*; ANSI-ISA 12.12.01 (Class I Div 2)*; ATEX/IEC Ex*; DNV GL (*pending)

3



Application example

Accessories

3



Push-in type jumper bar; light gray; insulated; 18 A		
Description	Item No.	Pack. Unit
2-way	859-402	200 (8x25)
3-way	859-403	200 (8x25)
4-way	859-404	200 (8x25)
5-way	859-405	200 (8x25)
6-way	859-406	100 (4x25)
7-way	859-407	100 (4x25)
8-way	859-408	100 (4x25)
9-way	859-409	100 (4x25)
10-way	859-410	100 (4x25)

Comb-style jumper bar; insulated		
	Item No.	Pack. Unit
2-way	281-482	100

Operating tool with a partially insulated shaft; Type 2; Blade: 3.5 x 0.5 mm		
	Item No.	Pack. Unit
	210-720	1

Item no. suffixes for colored push-in type jumper bars	
	Item No.
yellow	.../000-029
red	.../000-005
blue	.../000-006



End stop		
Width	Item No.	Pack. Unit
6 mm	249-116	1
10 mm	249-117	1
14 mm	249-197	1

Test pin		
	Item No.	Pack. Unit
	735-500	1

Marking

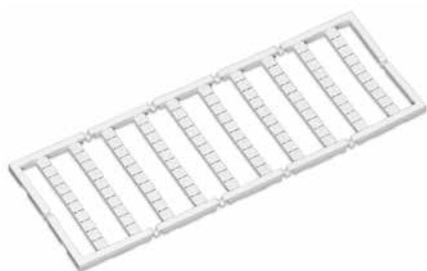

WMB Multi Marking System		
Marking	Item No.	Pack. Unit
plain	793-501	5 cards
1 ... 10 (10 x)	793-502	5 cards
11 ... 20 (10 x)	793-503	5 cards
21 ... 30 (10 x)	793-504	5 cards
31 ... 40 (10 x)	793-505	5 cards
41 ... 50 (10 x)	793-506	5 cards
1 ... 50 (2 x)	793-566	5 cards

Marking Strip for TOPJOB® S; white; plain; 11 mm wide		
	Item No.	Pack. Unit
50 m reel	2009-110	1